

Dear Client,

Thank you for Purchasing our UHV-H100P High Precision Contact Resistance Tester. Please read the manual in detail prior to first use, which will help you use the equipment skillfully.



Our aim is to improve and perfect the company's products continually, so there may be slight differences between your purchase equipment and its instruction manual. You can find the changes in the appendix. Sorry for the inconvenience. If you have further questions, welcome to contact with our service department.



The input/output terminals and the test column may bring voltage, when you plug/draw the test wire or power outlet, they will cause electric spark. PLEASE

CAUTION RISK OF ELECTRICAL SHOCK!

◆ **SERIOUS COMMITMENT**

All products of our company carry one year limited warranty from the date of shipment. If any such product proves defective during this warranty period we will maintain it for free. Meanwhile we implement lifetime service. Except otherwise agreed by contract.

◆ **SAFETY REQUIREMENTS**

Please read the following safety precautions carefully to avoid body injury and prevent the product or other relevant subassembly to damage. In order to avoid possible danger, this product can only be used within the prescribed scope.

Only qualified technician can carry out maintenance or repair work.

--To avoid fire and personal injury:

Use Proper Power Cord

Only use the power wire supplied by the product or meet the specification of this produce.

Connect and Disconnect Correctly

When the test wire is connected to the live terminal, please do not connect or disconnect the test wire.

Grounding

The product is grounded through the power wire; besides, the

ground pole of the shell must be grounded. To prevent electric shock, the grounding conductor must be connected to the ground.

Make sure the product has been grounded correctly before connecting with the input/output port.

Pay Attention to the Ratings of All Terminals

To prevent the fire hazard or electric shock, please be care of all ratings and labels/marks of this product. Before connecting, please read the instruction manual to acquire information about the ratings.

Do Not Operate without Covers

Do not operate this product when covers or panels removed.

Use Proper Fuse

Only use the fuse with type and rating specified for the product.

Avoid Touching Bare Circuit and Charged Metal.

Do not touch the bare connection points and parts of energized equipment.

Do Not Operate with Suspicious Failures

If you encounter operating failure, do not continue. Please contact with our maintenance staff.

Do Not Operate in Wet/Damp Conditions.

Do Not Operate in Explosive Atmospheres.

Ensure Product Surfaces Clean and Dry

— **Security Terms**

Warning: indicates that death or severe personal injury may result if proper precautions are not taken

Caution: indicates that property damage may result if proper precautions are not taken.

CONTENTS

1. Product Overview	6
2. Design use	7
3. Implementation Standards	7
4. Performance Features	7
5. Technical specifications	8
6. Panel structure	9
7. Working Principle	10
8. Operation method	11
9. Upper computer software	15
10. Micro printer operating instructions	20
11. Fault phenomenon and troubleshooting	22
12. Cautions	23
13. Packing list	23
Appendix I: Basic knowledge of contact (circuit) resistance	24
Appendix II: Circuit breaker conductive contact (circuit) resistance standard reference values	26

1. Product Overview

At present, the conventional QJ44 double-arm DC bridge is commonly used in power systems to measure contact resistance, and the test current of this type of bridge is only mA level, making it difficult to find defects in the reduced cross-sectional area of the circuit conductor. When measuring the contact resistance of the conductive circuit of high-voltage switches, the measured value is several times larger due to the influence of the oil film and oxide layer between the contacts, which cannot truly reflect the contact resistance value. For this reason, the latest Ministry of Electric Power standard DL/T845.4-2019 "General technical conditions of resistance measuring device: circuit resistance tester" and the new version of the testing regulations JJG1052-2009 "circuit resistance tester, direct resistance instrument testing regulations" made to measure the contact resistance of (disconnect) switches, circuit breakers, etc. The measurement current is not less than DC 100A, and the minimum current maintenance time is not less than 60S. The minimum current maintenance time is not less than 60S to ensure accurate test results. The instrument operation panel adopts ergonomic design, in line with operating habits, using high-frequency switching power supply and digital circuit technology, suitable for measuring the circuit resistance of switch control equipment. The test current adopts the DC 100A recommended by the national standard. 100A DC can be measured directly in the case of circuit resistance, test results with a large LCD display, and data storage, output printing, time setting and other functions, and another 50A gear for user selection; is the only domestic contact resistance tester that can reach $0.01\mu\Omega$ resolution and is very stable, with performance exceeding that of imported high-current Micro-ohmmeter. It meets the requirements of electric power and power supply departments for on-site high-voltage switch maintenance and high-voltage switch factory circuit resistance testing.

2. Design use

Suitable for high and low voltage switch contact (circuit) resistance, cable line DC resistance value of high precision measurement, also suitable for other occasions requiring high current, micro-resistance measurement.

3. Implementation Standards

Serial number	Standard name
1	DL/T845.4-2019 General technical conditions for resistance measuring devices: circuit resistance tester
2	DL/T596-2021 Preventive test procedures for power equipment
3	JJG1052-2009 Loop resistance tester, direct resistance instrument calibration procedures
4	DL/T967-2005 Circuit resistance tester and DC resistance fast tester testing procedures

4. Performance Features

1. High current: Using the latest switching power supply technology, it can continuously output high current for a long time, overcoming the drawback of pulse type power supply instantaneous current, which can effectively break through the switch contact oxide film and get good test results.

2. High stability: Under severe interference conditions, the last data of the

LCD screen can be stable within ± 1 word, with stable readings and good repeatability.

3. High precision: Adopt double-way high-speed 16-bit Σ - Δ AD sampling, the latest digital signal processing technology, the highest resolution of $0.01\mu\Omega$, is the only domestic contact resistance tester can reach $0.01\mu\Omega$ resolution and very stable, the performance exceeds the imported high-current micro-ohmmeter.

4. Intelligent: imported high-performance CPU, the system automatically switches the range according to the signal size when measuring to ensure the accuracy of the test. Over-temperature protection circuit can automatically stop the output current when the instrument exceeds the set temperature to ensure the safe use of the instrument.

5.High quality: All key components are imported, and the temperature compensation circuit is cleverly designed to effectively eliminate the influence of ambient temperature on the measurement results, and the use of military connectors enhances the vibration resistance.

6. Powerful: free choice in current 50A, 100A, test time in fast, 10 seconds, 30 seconds, 60 seconds, any choice, far more than the performance of other similar instruments.

7. Friendly human-machine interface: touch screen control, convenient and fast, independent setting of the instrument date and time, real-time saving of measurement data, instant printing of measurement results.

8. USB transfer: transfer measurement data to U disk through USB interface, combined with the upper computer software for further analysis and processing of measurement data.

9. Easy to use: small size, light weight, easy to carry.

5. Technical specifications

1、 Measurement range: 50A 0~10m Ω

100A 0~5mΩ

2、Resolving power: 0~99.99μΩ 0.01μΩ

100.0~10000.0μΩ 0.1μΩ

3, test flow: DC50A, 100A two fixed output

4、 Measurement accuracy: $\pm(0.5\% rd+2d)$

5, working time optional: fast, 10 seconds, 30 seconds, 60 seconds

6, display mode: 4 inch touch screen

7、 Communication mode: U disk to store

8、 Working power: AC220V \pm 10% 50Hz

9, the whole machine power: 600W

10, the maximum storage records: 200

11, working environment: temperature -10 °C ~ 40 °C humidity \leq 80 % RH

12、 Body size: 390×300×150 mm³

13、 Weight: 6kg (without accessories)

6. Panel structure

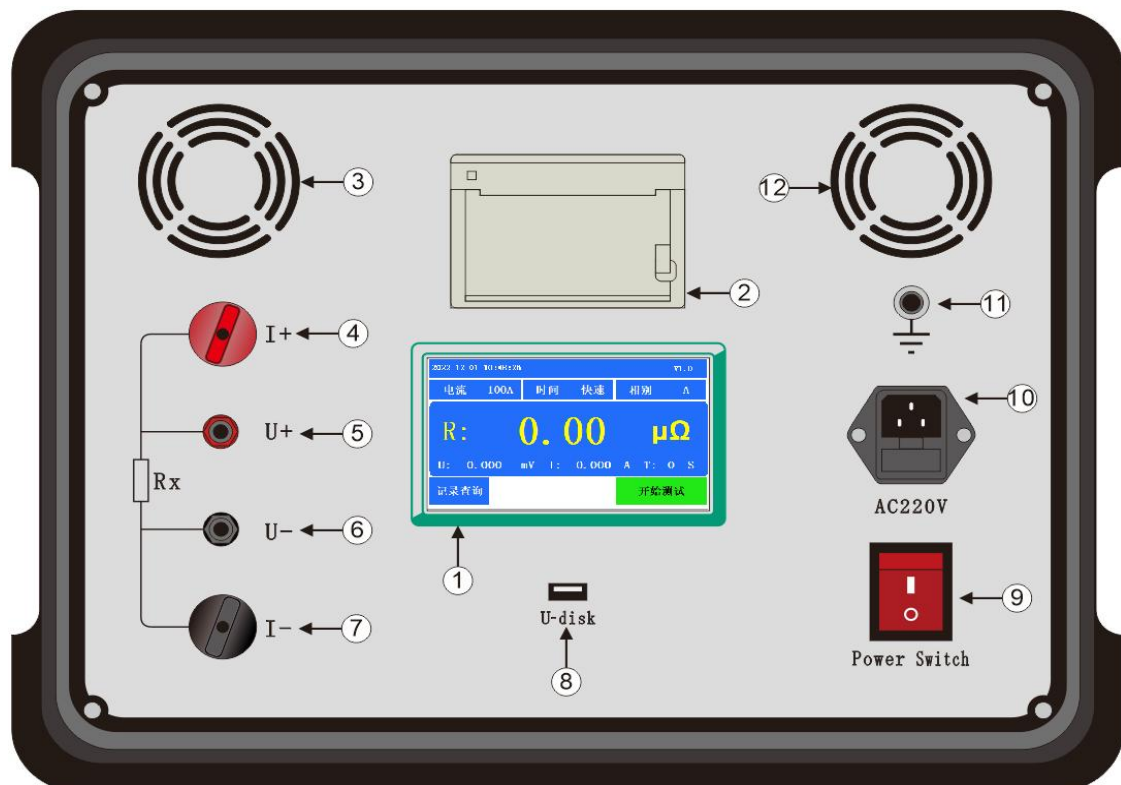

Panel Structure Diagram

- | | | |
|----------------------|---------------------|-----------------------|
| 1、 Touch Screen | 2、 Printers | 3、 Fan outlet |
| 4、 Current output I+ | 5、 Measure input U+ | 6、 Measure input U- |
| 7、 Current output I- | 8、 USB interface | 9、 Power Switch |
| 10、 Power outlets | 11、 Grounding post | 12、 Ventilation holes |

7. Working Principle

This instrument uses the current-voltage method test principle, also known as the four-wire method test technique, the principle block diagram is shown in

Figure 2.

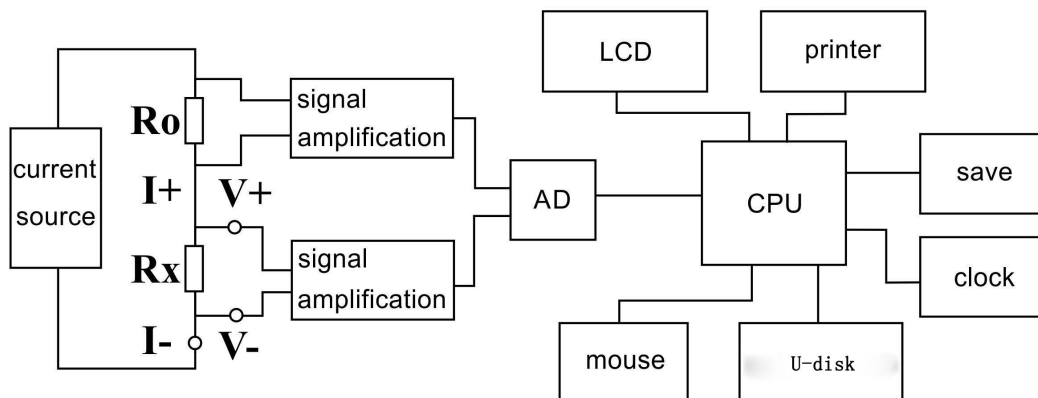

Figure 2 Test schematic

The current source outputs a constant current flowing through the standard resistor R_0 and the resistor to be measured R_x . The voltage signal U_0 on the standard resistor R_0 is sampled, filtered and amplified, and then

sent to the AD for conversion to a digital quantity, which in turn calculates the current value I , as shown in Equation (1). Similarly, the voltage signal U_x on the resistor R_x to be measured is sampled, filtered, multi-stage amplified and sent to the AD for conversion to a digital quantity, and the resistance value R_x is calculated by equation (2).

$$I = \frac{U_0}{R_0} \quad (1)$$

$$R_x = \frac{U_x}{I} \quad (2)$$

8. Operation method

1、 LCD display instructions

The instrument adopts 480×272 high resolution touch screen, which can be clearly displayed even under strong sunlight. The parameter settings and test results are displayed on the LCD screen. Full Chinese character operation interface, clear graphics, beautiful and easy to operate.

2、 Correct wiring

Wire correctly according to the wiring method shown in Figure 3.

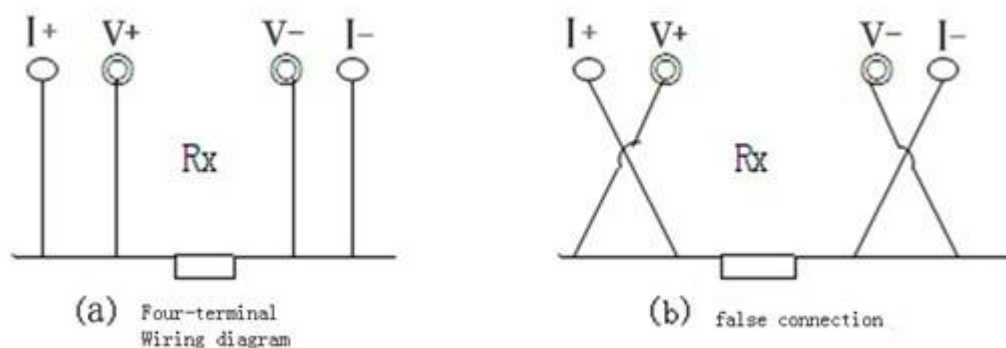

Figure 3 Four terminal wiring diagram

Attention: ①The connection between the instrument panel and the test line should be twisted tightly, and there should be no loose phenomenon.

②Wiring in accordance with the four-terminal method, i.e., the current line is clamped on the outside of the test item, the voltage line is clamped on the inside of the test item, and the current and voltage must be of the same polarity.

3、 Power on

After confirming that the test line is wired correctly, access the 220V AC power supply, close the power switch, and the instrument enters the power-on state.

4、 Main Interface

Turn on the power switch and the system enters the main interface.



5、 Test menu interface

In the main interface Click the date and time in the upper left corner: you can set the system time.

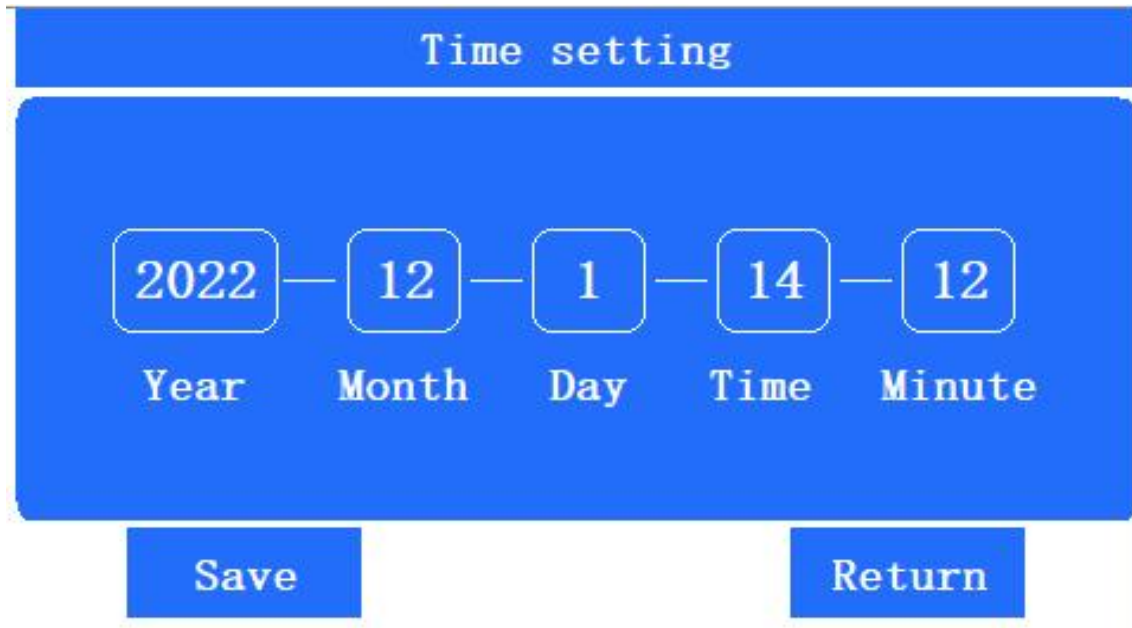

Click "Current": 50A, 100A buttons appear for selection.



Click "Time": Fast, 10S, 30S, 60S buttons appear for selection.

Click "Phase": A, B, C buttons appear for selection.

Click "Start Test": the instrument starts to output current, and stops automatically when the set time is reached and the save and print button appears.

Note: At this time there is a large current flowing on the current line, do not force the current line off, otherwise it may cause harm to the

operator and the instrument.

2022-12-01 14:42:04		V1.0						
Current	100A	Time	10S	Phase	A			
R: 75.08 $\mu\Omega$								
U:	7.499	mV	I:	99.912	A	T:	10	S
Record	Save	Print	Start Test					

Note: If the measured value exceeds the measurement range, the LCD screen will display "Out of measurement range", and if the current line is not connected or the signal input line is reversed, it will display "Wiringerror".

2022-12-01 14:42:04		V1.0						
Current	100A	Time	10S	Phase	A			
R: 75.08 $\mu\Omega$								
U:	7.499	mV	I:	99.912	A	T:	10	S
Record	Save	Print	Start Test					

Click "Save": Save the test data.

Click "Print": Print out the test data directly.

Click "Record Query": You can query the history records, print or transfer

toUdisk.

Record			
Number	Phase	Resistance	Test Time
A001	A	75.08 $\mu\Omega$	2022-12-01 14:42:02

Open

USB dump

Delete

Return

Page up 1 / 1 Page down

Click "Open File": First select the line you want to open and then click Open File to open the test record.

Test record	
Test Resistance:	75.08 $\mu\Omega$
Test Current:	99.912A
Test Time :	10S
Test Number:	A001
Phase:	A
	2022-12-01 14:42:02

Print

Return

9. Upper computer software

1、Software Function Introduction

This supporting tool software can import the measurement data

transferred to the USB flash drive through the instrument for the testers to do further analysis of the measurement data.

2、 Software Features

- This software is green and can be used without installation
- Supports all Windows operating systems

3、 Operating Environment

Hardware equipment requirements.

Celeron 533 and above CPU, 512MB and above RAM, 1GB and above available hard disk space are recommended.

Support software.

Windows series operating systems such as Win98, Win2000, XP, Win2003, Vista, Win7, Win8.

Microsoft Office 2000 and above (must include Excel).

4、 Introduction of the random USB drive file

Open the randomly configured USB flash drive, copy the folder inside the flash drive to the local computer, and open the file directory as shown in Figure 23.

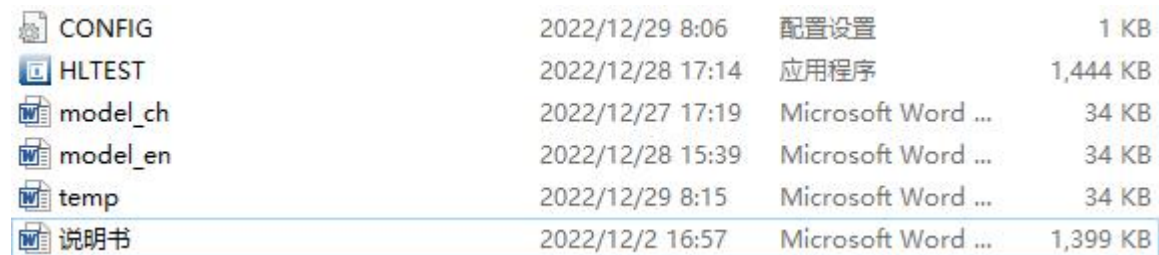

CONFIG	2022/12/29 8:06	配置设置	1 KB
HLTEST	2022/12/28 17:14	应用程序	1,444 KB
model_ch	2022/12/27 17:19	Microsoft Word ...	34 KB
model_en	2022/12/28 15:39	Microsoft Word ...	34 KB
temp	2022/12/29 8:15	Microsoft Word ...	34 KB
说明书	2022/12/2 16:57	Microsoft Word ...	1,399 KB

Figure 23 Loop installer USB disk directory

5、 Software operation instructions

1) Double click  HLTEST 2022/12/28 17:14 应用程序 1,444 KB , Run the circuit (contact) resistance tester companion tool software, as shown in Figure 24.

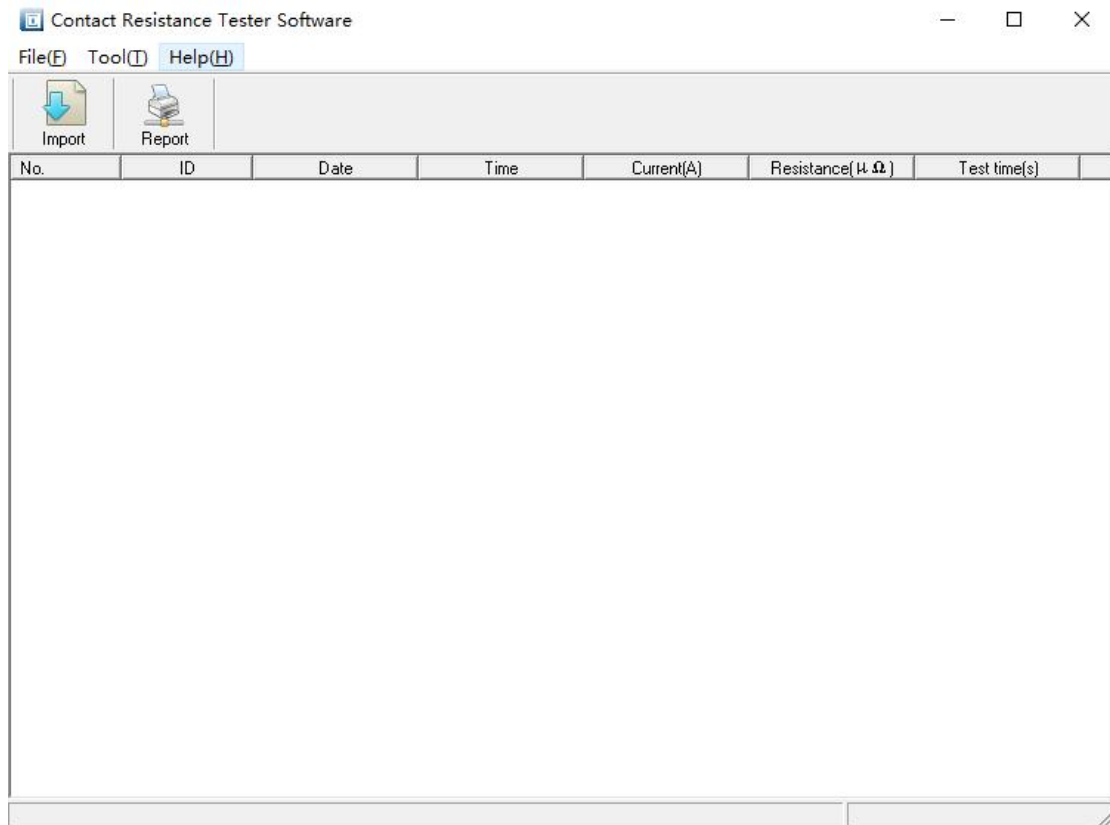

Figure 24 loop (contact) resistance tester supporting tool software interface

(2) Import data: Insert the USB flash drive, click the "Import Data" button, click the file name to be imported, as shown in Figure 25, click Open to enter the import success interface, as shown in Figure 26.

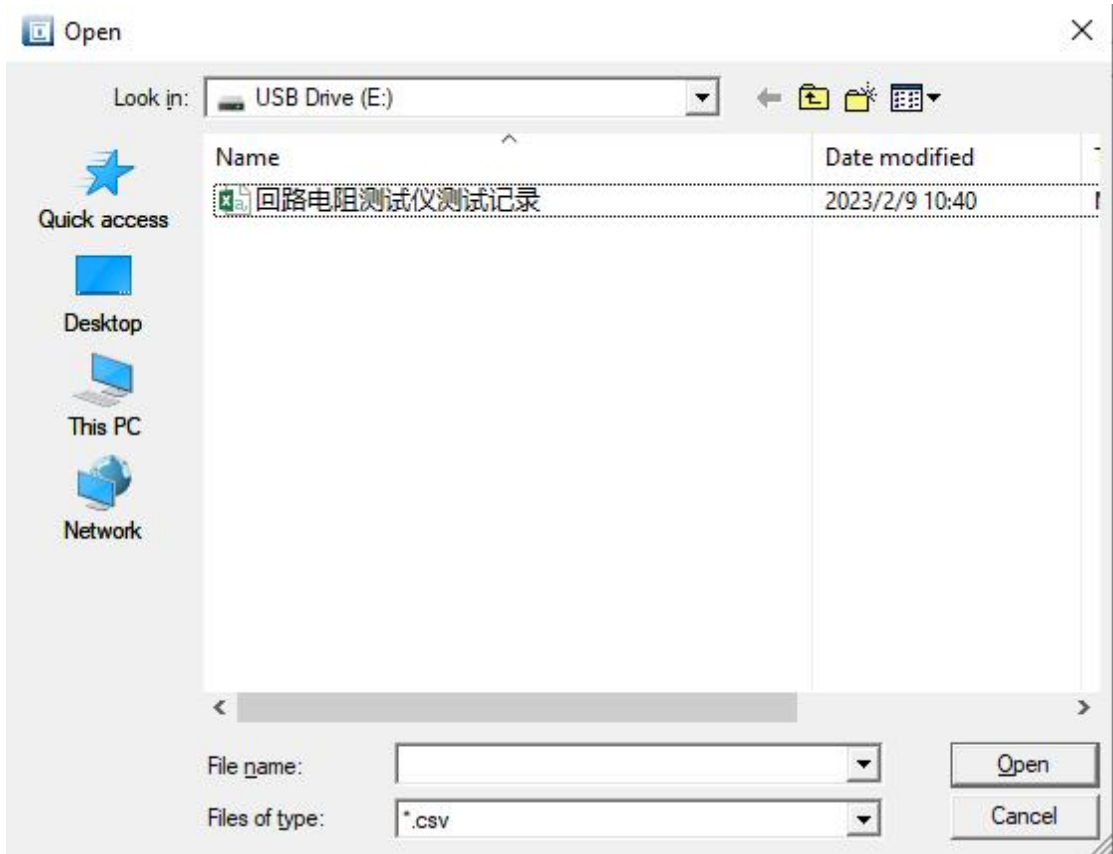

Figure 25 Importing date

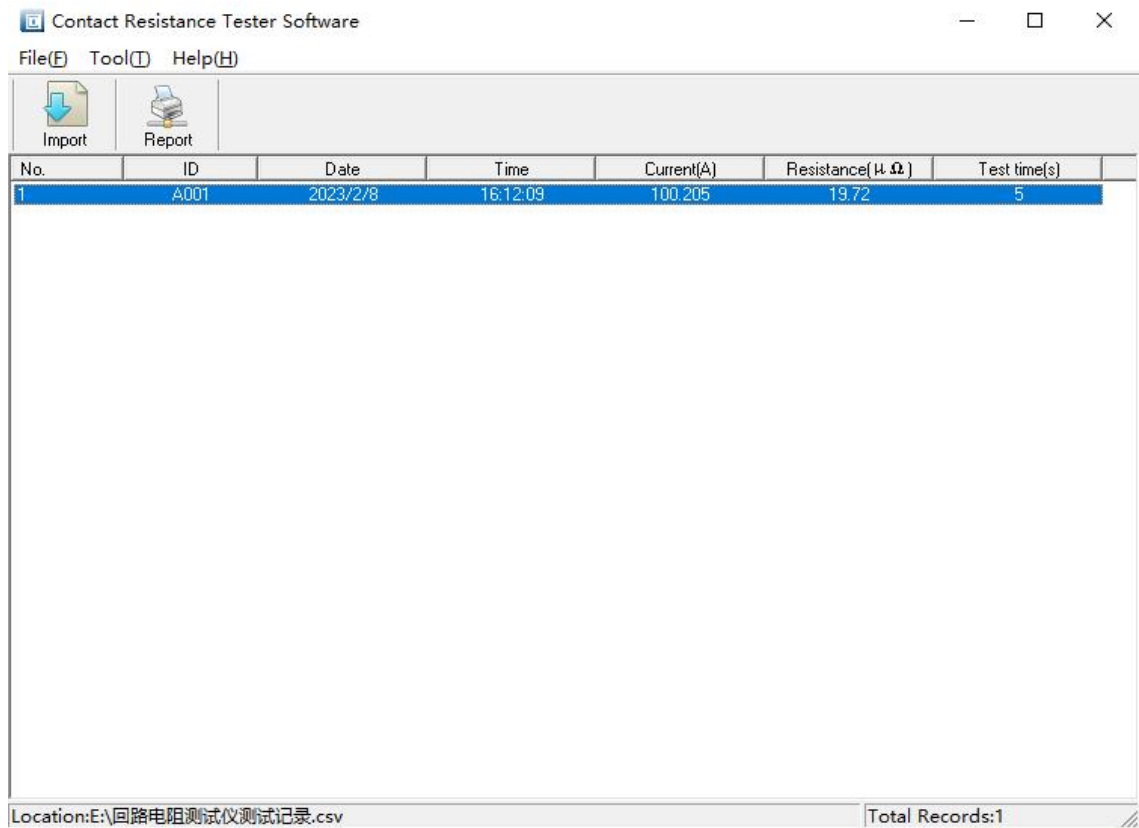

Figure 26 Successful import

3) Generate Report: In Figure 26, select one of the records and click the "Generate Report" button to generate a report in word format for that record, as shown in Figure 27.

Test Report

Equipment NO.: _____

Test Result			
Test NO.	A001	Test Date	2023/2/8 16:12:09
Resistance ($\mu\Omega$)	19.72	Current (A)	100.205
Test Time (s)	5	Phase	A
Test Conclusion:			
Remarks:			
Tester			
Checker		Check Date	

Figure 27 Generating reports

10. Micro printer operating instructions

Paper loading operation

1. Toggle the front cover button to open the front cover of the printer and take out the remaining paper core

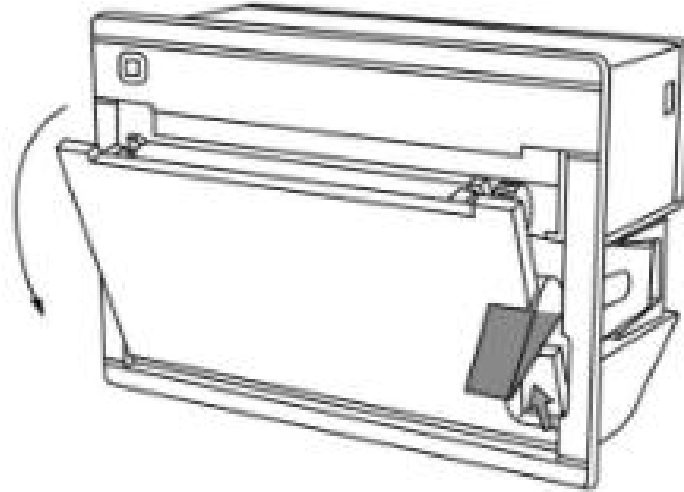

2. Put in new paper roll

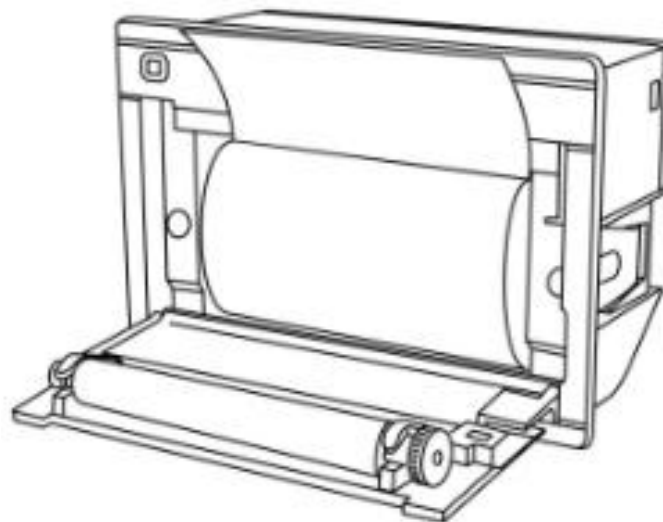

3.Pull out part of the paper head, put it in the center position, and close the front cover

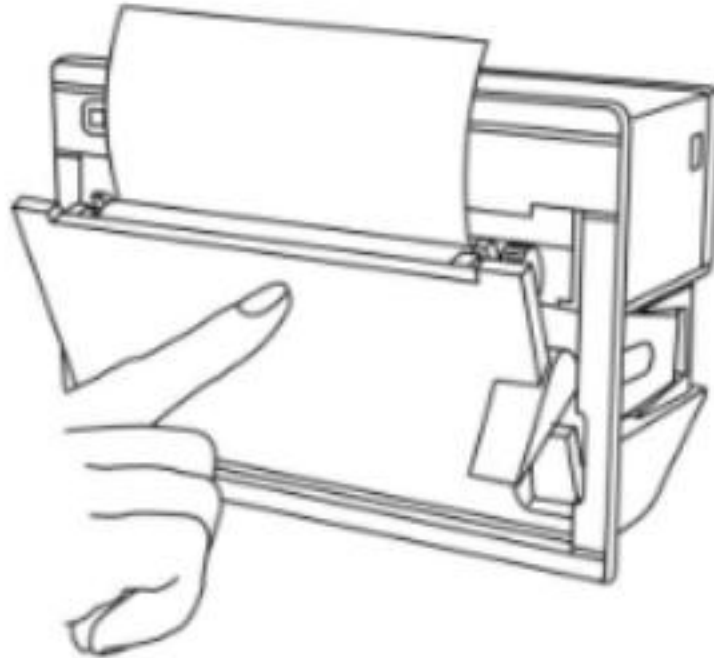

Note: When closing the front cover, let the paper stick out from the paper outlet for a section so that the adhesive spindle can fully press the paper roll, otherwise it will not print. Thermal type printer on the paper, you must confirm the thermal printing paper thermal coating on the top, and then the thermal paper into the printer bin, if the thermal layer is not on top of the print does not print out. If the print paper goes off, you can reopen the front cover and adjust the print paper position.

11. Fault phenomenon and troubleshooting

Fault phenomenon	fault troubleshooting
No response after power on, no display on LCD screen	Check the availability of AC power
	Check the power cable
	Check if the fuse in the three-core socket is burnt out
Significantly large resistance value during testing or displayed as over-range	Check if the measured resistance value is too large
	Check whether the voltage input line is connected to the inner side of the current output line
	Check whether the polarity of the test line is reversed
	Check whether the voltage output line is connected and whether the connector of the tested part is oxidized
	Check whether the test piece is closed
USB flash drive dump unsuccessful	Multimeter beeping gear to check whether the test line ports are in good contact
	Turn off the power and reboot
	Replace the new USB flash drive

12. Cautions

- 1、 Please read the manual carefully before using the instrument.
- 2、 Please follow the correct wiring method in the manual.
- 3、 The instrument must not test the circuit resistance in the charged circuit.
- 4、 The instrument must be reliably grounded in use.
- 5、 Do not replace the current line at will.
- 6、 The instrument should be kept in a ventilated, dry, cool and clean place when not in use, and pay attention to moisture and corrosive gases.

13. Packing list

1. main machine	1 set
2. special test line (high current test line 6m two, high current test clip two, voltage test line 6m two)	1 set
3. grounding wire	1pc
4 AC 220V power cord	1 root
5. 5A fuse	3pcs
6. U disk	1pc
7. Accessories package	1pc
8. Product manual	1pc
9. Printing paper	4 rolls
10. Factory inspection report	1 copy
11. Certificate of conformity	1 copy

Appendix I: Basic knowledge of contact (circuit) resistance

1. What is contact resistance?
2. Contact resistance is the additional resistance that occurs when the static contacts and dynamic contacts contact each other.
3. What are the parts of contact resistance of circuit breaker?
4. By moving, static contact contact part of the contraction resistance and surface resistance of two parts.
5. the circuit breaker contact resistance of the reasons for failure?
6. Contact burnout when opening larger short-circuit current.
7. Poorly adjusted due to poor institutional fixation, resulting in travel changes, when the overtravel is seriously unqualified, causing changes in contact pressure or contact area.
8. After the commissioning and installation of the circuit breaker, it is not put into operation for a long time, so that the dynamic and static contact surface oxidation, contact surface resistance increases.
9. -Long-term operation makes the spring deformation, so that the contact pressure decreases.
10. Mechanical wear caused by long-term operation of mechanical parts.

11. For less oil circuit breakers, may also be due to the insulating oil acid value is not qualified acidic reaction, leaching contact surface. Or floating impurities in the oil, moving, static contacts between the residual particles of carbon and metal powder due to the opening and closing of the short-circuit current, so that the contact resistance increases.

12. the factors affecting the contact resistance?

13. Material properties: hardness, chemical properties, mechanical strength and resistivity of metal compounds.

14. Contact form: point contact, line contact, surface contact.

15. Contact surface condition: when the contact surface to form an oxide film (silver exception), the oxide film than the resistance of the metal itself is much greater.

16. Contact pressure.

17. The roughness of the contact surface.

Appendix II: Circuit breaker conductive contact (circuit) resistance standard reference values

Model No. Circuit resistance per phase	Model No. Circuit resistance per phase	Model No. Circuit resistance per phase	Model No. Circuit resistance per phase
SN1-10	<95	DW1-60G	200
SN2-10G	75	SW1-110	700
SN4-10	50~60	SW2-110I	180
SN4-20	50~60	SW3-110	160
SN4-10G	20	SW4-110	300
SN4-20G	20	SW6-110	180~220
SN5-10	100	SW2-220	400
SN6-10	80	SW4-220	600
SN10-35	<75	SW6-220	<400
DW1-35	550	SW7-220	<190
DW1-60	500	KW1-220	400
DW3-110	1100~1300	KW2-220	170
DW2-110	800	KW3-220	110
KW1-110	150	KW4-220	130
KW3-110	45	DW2-220	1520
KV4-110A	60	DW3-220	1200
DW3-110G	1600~1800	SW6-330	>600

