

Dear Client,

Thank you for Purchasing our PDF-1000 DC System Earth Fault Detector. Please read the manual in detail prior to first use, which will help you use the equipment skillfully.



Our aim is to improve and perfect the company's products continually, so there may be slight differences between your purchase equipment and its instruction manual. You can find the changes in the appendix. Sorry for the inconvenience. If you have further questions, welcome to contact with our service department.



The input/output terminals and the test column may bring voltage, when you plug/draw the test wire or power outlet, they will cause electric spark. PLEASE

CAUTION RISK OF ELECTRICAL SHOCK!

Company Address:

- ◆ **T4, No. 1, High-tech 2 Road, East Lake High-tech Development Zone, Wuhan**
- ◆ Sales Hotline: 86-27- 87492243
- ◆ After Service Hotline: 86-27- 87459656
- ◆ Fax: 86-27- 87803129
- ◆ E-mail: whhuation@163.com
- ◆ Website: www.whhuation.com

◆ **SERIOUS COMMITMENT**

All products of our company carry one year limited warranty from the date of shipment. If any such product proves defective during this warranty period we will maintain it for free. Meanwhile we implement lifetime service.

◆ **SAFETY REQUIREMENTS**

Please read the following safety precautions carefully to avoid body injury and prevent the product or other relevant subassembly to damage. In order to avoid possible danger, this product can only be used within the prescribed scope.

Only qualified technician can carry out maintenance or repair work.

--To avoid fire and personal injury:

Use Proper Power Cord

Only use the power wire supplied by the product or meet the specification of this produce.

Connect and Disconnect Correctly

When the test wire is connected to the live terminal, please do not connect or disconnect the test wire.

Grounding

The product is grounded through the power wire; besides, the ground pole of the shell must be grounded. To prevent electric shock, the grounding conductor must be connected to the ground.

Make sure the product has been grounded correctly before connecting with the input/output port.

Pay Attention to the Ratings of All Terminals

To prevent the fire hazard or electric shock, please be care of all ratings and labels/marks of this product. Before connecting, please read the instruction manual to acquire information about the ratings.

Do Not Operate without Covers

Do not operate this product when covers or panels removed.

Use Proper Fuse

Only use the fuse with type and rating specified for the product.

Avoid Touching Bare Circuit and Charged Metal.

Do not touch the bare connection points and parts of energized equipment.

Do Not Operate with Suspicious Failures

If you encounter operating failure, do not continue. Please contact with our maintenance staff.

Do Not Operate in Wet/Damp Conditions.

Do Not Operate in Explosive Atmospheres.

Ensure Product Surfaces Clean and Dry.

— Security Terms

Warning: indicates that death or severe personal injury may result if proper precautions are not taken

Caution: indicates that property damage may result if proper precautions are not taken.

Contents

I. Overview	6
II. Principle	7
III. Specifications	8
IV. Structure and Function of Instrument	9
V. Notes	12
Appendix 1: structural representation	14
Appendix 2: brief method introduction	15

I. Overview

This product is DC ground fault tester of new generation. It applies to all DC system in any voltage class, equipped with high-precision measured clamp meter, expanded the measured range and strengthened the anti-interference ability by processing many kinds of signal. Adopted excellent method of calculation and advanced Fuzzy control calculation theory, show us the advancement of the measured circuit branch by numerical value, which reflect the superiority of artificial intelligence sufficiently. Correctly detect the position of the ground point each time.

This equipment take system safety as primary premise uses reliable low frequency signal method to test according the highest requirements of industry standard, and put into practice for test on site, no effects to system.

The DC system of power plant and transformer substation is the power supply for control, protect, signal and auto equipment, the safe continuous running is very important to generate and supply power. The DC system is overhead ungrounded system, it will induce the mentioned device wrong or failure to act if there was two points grounded. So correctly and fast to detect the ground contact, clearing of the ground fault meanwhile ensure the DC system normally supply power, to avoid the damage caused by two points grounded.

This device applies to detect the accurate ground point position of power plant, transformer substation DC system. Accuracy up to 100%.

This device with the bellowing advantages compared with the same type devices:

1. Easy to use, customers can directly operate only need turn on the power switch.
2. Safe and reliable, do not need power off the charger or other power source, without effects to DC system.
3. Applies to various voltage class, DC system V, 110V, 48V, 24V.

4. Wide range of application, any power plant, transformer substation, colliery, chemical plant and others power supply departments.

5. Easy to carry, the signal receiver equipped with battery, do not need external power source.

6. DC system do not need power off when searching the ground point, do not affect the normal work of the system.

7. Strong anti-jamming ability, without the effects by system distributed capacitance.

8. Intelligent charge management, shorten the charging time, lengthen the battery life.

II. Principle

This device applies to detect the accurate ground point position of power plant, transformer substation DC system. It uses new method: waveform analysis, its features and advantages: high measurement sensitivity, detection under no power interruption, no effect to system normal work, strong anti-jamming ability, safe and reliable.

Waveform analysis : inject one special cyclical voltage signal between DC bus bar and ground, detect the current of each branch using caliper probe, analyze and calculate phase and phase difference of current signal fundamental wave and harmonic wave, and then judge if there was ground fault or ground fault contact.

This device is composed by signal generator, signal receiver and signal sampler (caliper). These three parts should be matched use when detect the DC ground fault.

This signal generator adopts new digital technique instead of using traditional LC or RC oscillation circuit, it with the features of stable signal. This signal generator is composed by single chip, A/D converting circuit, signal amplifying filter circuit, power amplifying & blocking circuit, output feedback and protection, its principle as follow:

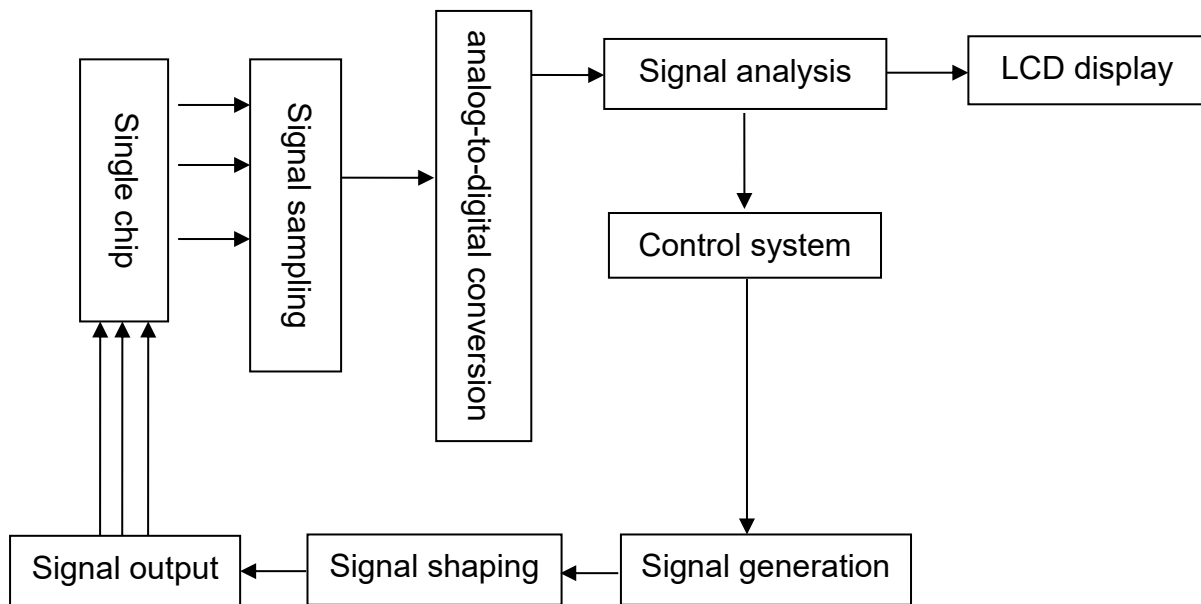

Signal generator principle

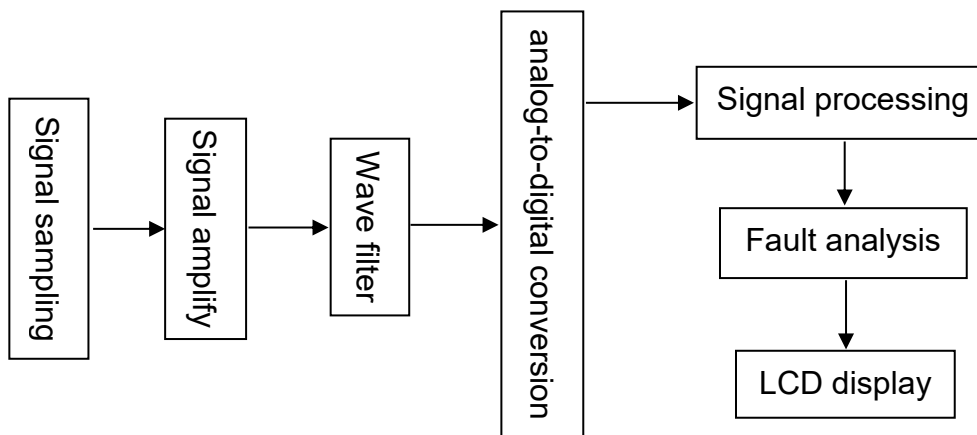

Signal receiver principle

III. Specifications

1. Signal generator:

Output signal frequency: 2.5Hz

Signal no-load output voltage: $\pm 20V \pm 5\%$

Signal voltage amplitude error: $< 5\%$

Signal short circuit output current: $\leq 80mA$

Output terminal shock resistance capability: 400V DC impulse

Supply voltage: AC220V $\pm 15\%$

Voltage frequency: 50Hz

Input fuse: 200mA

Maximum power: 3W

Dimension: 300x270x200mm

2. Signal receiver

Signal current measurement sensitivity: 0.5mA

Impedance of signal receiver: 40KΩ

Maximum output current: 2.5mA

Display of receiver: number 0-19

Dimension: 210x100x32mm

A jaw size: Φ50mm

B jaw size: Φ7mm×9mm

3. Complete appliance

Measured maximum ground resistance: 300kΩ

Ground resistance measurement accuracy: 0-4.5KΩ; error≤0.5KΩ

IV. Structure and Function of Instrument

1. Composition

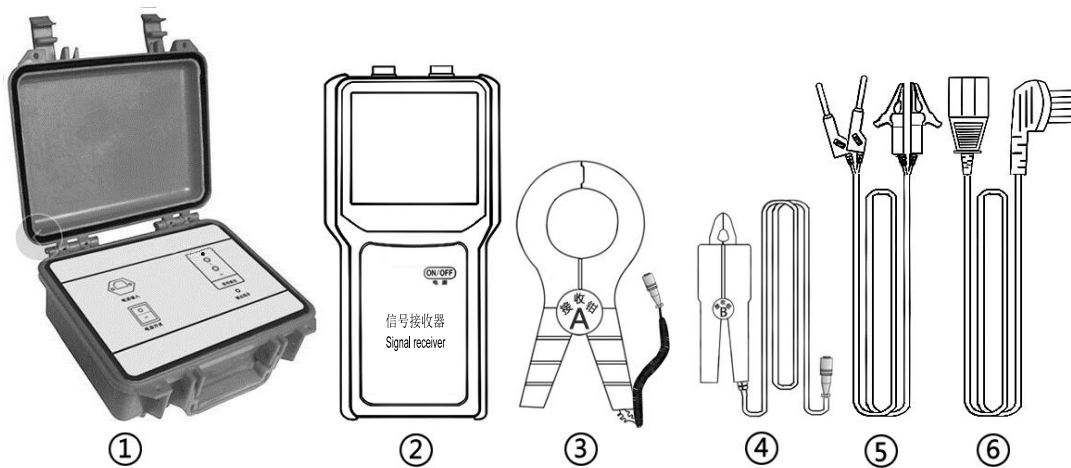

① Signal generator

② Signal receiver

③ A clamp (big)

④ B pliers (small)

⑤ signal output lead

⑥ Power cord

2. Signal generator

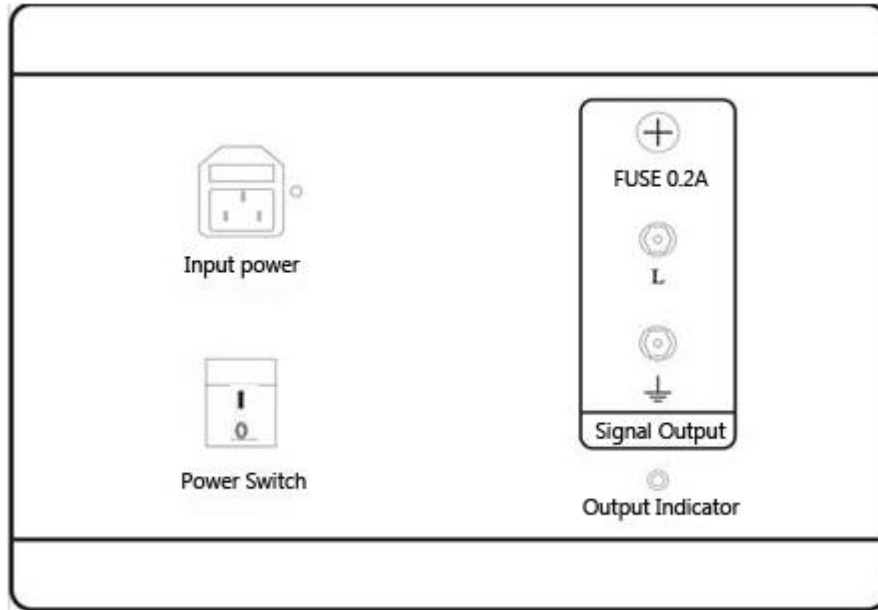

Fig. 1 Panel layout of signal generator

Input power: When signal generator connects to ACV power supply, it can work. There is a fuse (2A) at the bottom of power outlet.

Power switch: Press the end "I" of power switch to start up the instrument; press the end "O" of power switch to shut down the instrument.

Output indicator: Turn on power supply, signal generator will output signal, if signal output is normal, the output indicator will flash indicating having normal low-frequency voltage output.

Signal output: the port for signal output. When using, please insert output leads to output signal.

Access signal generator:

Insert signal output leads into signal generator, red clip connects to bus bar; black clip connects to earth lead. Confirm all wire are well connected; turn on power switch of signal generator.

According to the status of DC system ground fault, let signal generator closely connect to bus bar and earth lead of the battery output terminal. Having detected earthed branch but its loop slips far away, in order to improve detection accuracy, let signal generator connect to DC insurance port of branch top that close to fault region, or connect to DC bus bar at the bottom of

loop. When detecting, signal generator should be always connected to power supply terminal of DC branch, and the fault detector and the signal receiver are always testing at the load end of DC branch.

3. Signal receiver

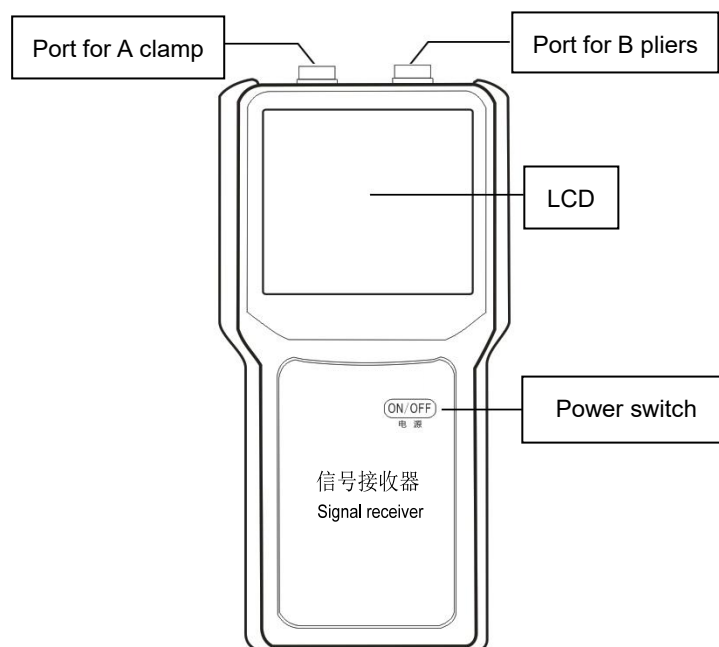

Fig.2 Panel layout for signal receiver

Port for A clamp: Connect "A" clamp, the clamp is big clamp.

Port for B pliers: Connect "B" pliers, this clamp is a small pliers.

LCD: dot matrix LCD display.

Power switch: Press "ON / OFF" key to start up/shut down.

Instructions for Signal receiver:

With calipers respectively clamp all main circuit that were associated with fault bus bar, and then observe LCD display. Use number 0-19 from low to high to indicate insulation value, "01" indicating poor insulation, "19" indicating good insulation. When LCD displays a lower value, you can judge fault is on this main circuit, and then with calipers measure branch circuit that linked to faulted main circuit, through LCD display value you can determine broken branch, and so on, using the same method can find the final faulted branch.

Found the earthed branch, for the fault point you can do location detection. When testing, user can use dichotomy to detect faulted area. In each test, the faulted area will do the next location detection according to dichotomy, in order

to quickly detect the specific fault grounded point. Assume that find ground fault at A place, and not find at B place, we can determine the fault grounded point is between A and B. According to feeder cables and equipment connections, you can respectively detect the entrances of feeder cables, and find fault branch, then further locate fault point.

The calipers can be used to measure current of bus bar and feeder cables; its sensitivity is extremely high. Because of its high sensitivity, when testing it is necessary that let the calipers firmly clamp the feeder cables, until obtain stable measured data.

4. Signal output lead

Red lead connects to fault bus bar terminal, black lead connects to ground. Red plug inserts into "L" terminal of signal generator, and the black inserts into "⏏" terminal.

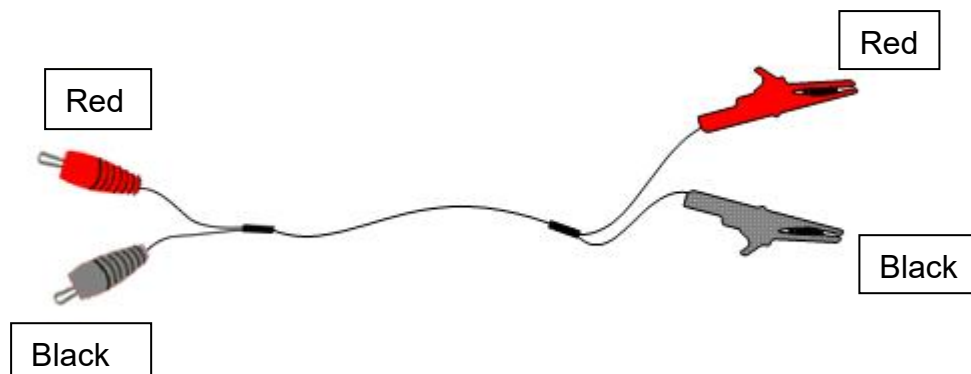

Fig. 3 Picture for signal output lead

V. Notes

1. The device is a precise instrument, when transport, use and store, it should be handled with care to prevent violent vibrations or shock.
2. Signal source should be added to fault bus bar and ground.
3. The calipers can only clamp DC circuit, cannot clamp AC circuit.
4. When there is no obvious ground point on each branch circuit, please check power supply part such as battery, charger and other parts.
5. During test, if not use please turn power off to extend battery life.

6. When signal receiver is low battery, please replace the battery timely to improve measurement accuracy.

7. Since the receiver has high sensitivity, when testing please do not grasp it, let the receiver in quiescent state, so as not to affect detection accuracy.

Appendix 1: structural representation

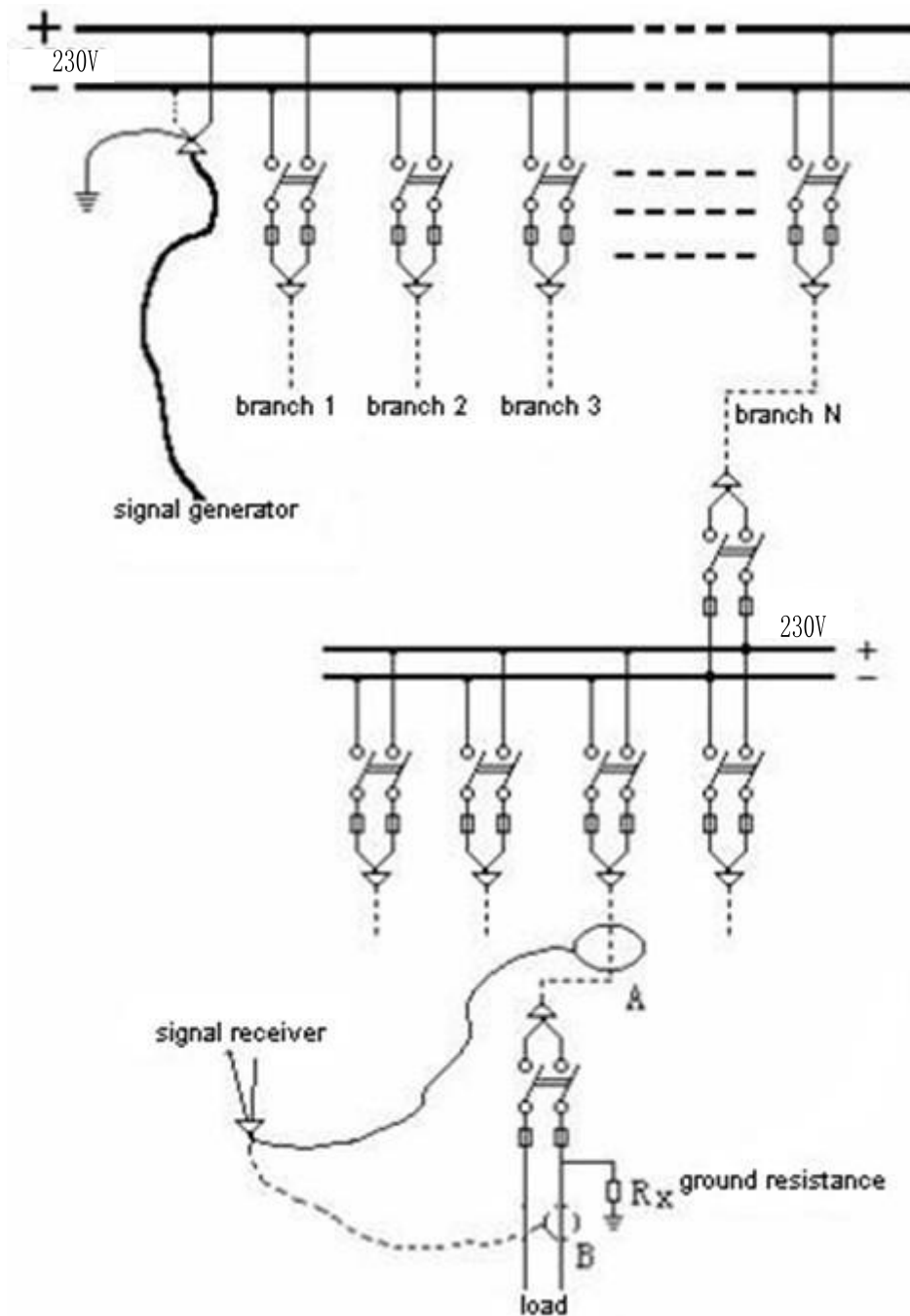

Appendix 2: brief method introduction

1. Connect the signal generator with bus bar
Red wire connect with “bus bar” (red clip) ; Black wire connects with “ground” (black clip);
2. Turn on the power switch of the signal generator.
3. Insert the plug of the caliper with the input jack of the signal receiver.
4. Turn on the power switch of the signal receiver.
5. Strangulate the measured circuit using caliper.
6. Begin to test.
7. The LCD display “number”, ground resistance display in number 01-19 (from low to high). “01” means the ground resistance is too small, “19” means well grounded, detect the grounded conditions according detailed value.

