

Dear Client

Thank you for Purchasing our HT2671A Insulation Resistance Tester. Please read the manual in detail prior to first use, which will help you operate the equipment skillfully.



Our aim is to continually improve and perfect the company's products, so there may be slight differences between your purchase equipment and its instruction manual. You can find the changes in the appendix. Sorry for the inconvenience. If you have further questions, welcome to contact with our service department.



The input/output terminals and the test column may bring voltage, when you plug/draw test wire or power outlet, they will cause electric spark. PLEASE CAUTION RISK OF ELECTRIC SHOCK! To avoid risk of electric shock, be sure to follow the operating instructions!

◆ **SERIOUS COMMITMENT**

Within three months from the date of delivery, if our products have quality defects, implementation of replacement; in one year (including one year), repair for free; more than one year, implementation of lifetime maintenance with charge. Except otherwise provided by contract.

◆ **SAFETY REQUIREMENTS**

Please read the following safety precautions carefully to avoid personal injury and to prevent the product or any other attached products being damaged. In order to avoid possible danger, this product can only be used within the scope of the provision.

Only qualified technician can carry out maintenance or repair work.

--To avoid fire hazard or personal injury:

Use Proper Power Cord

Only use the power wire supplied by the product or meet the specifications of this product.

Connect and Disconnect Correctly

When the test wire is connected to the charged terminal, please do not connect or disconnect the test wire at will.

Grounding

The product is grounded through the power cord; besides, the ground pole of the shell must be grounded. To prevent electric shock, the grounding conductor must be connected to earth ground. Before making connections to the input or output terminals of the product, please do check that the product is properly grounded.

Pay Attention to the Ratings of All Terminals

To prevent the fire hazard or electric shock, please be care of all ratings and labels/marks of this product. Before connecting, please read the instruction manual to acquire information about the

ratings.

Do Not Operate without Covers

Do not operate this product when covers or panels removed.

Use Proper Fuse

Only use the fuse with type and rating specified for the product.

Avoid Touching Bare Wire and Charged Conductor

Do not touch the bare connection points and parts of energized equipment.

Do Not Operate with Suspicious Faults

If you encounter operating faults/suspect there is damage to this product, do not continue. Please contact with our maintenance staff.

Do Not Operate in Wet/Damp Conditions.

Do Not Operate in Explosive Atmospheres.

Ensure Product Surfaces Clean and Dry.

— Security Terms

Warning: indicates that death or severe personal injury may result if proper precautions are not taken

Caution: indicates that property damage may result if proper precautions are not taken.

Contents

Precaution	5
Before Use	5
I.Features and functions	8
II. Specification	8
III. Diagram of the product	10
IV.LCD Display	12
V. Operation	13
Preparation before measurement	13
Voltage measurement	15
Insulation resistance measurement	17
Continuous Measurement	20
Green Guard wire usage	21
VI. Other items	22

Precaution

- Thank you for purchasing our company's insulation tester.
- This manual provides relative information on how to use the unit and warnings in operation.

to make the best use of the products *s functions read the manual throughly before use, Please keep the manual for quick reference.

- Please make some simple test measurement to ensure proper performance of the unit.

Before Use

Check Up

Carefully unpack your kit and ensure that you have the following items , in case that any item is missing or if you find any mismatch or damage ,promptly contact your dealer.

Insulation Tester.....	1pcs
Test wire、 Alligator clip.....	3pcs
1.5V AA Battery.....	6pcs
PP box.....	1pcs
English Instruction Manual.....	1pcs
Inspection Report.....	1pcs
Certification.....	1pcs

Safety Precaution



The instrument is designed to following standards

- IEC61010-I CAT.III 600V Type2
- IEC 61010-031 (Hand lever、 Probe standards)

 Warning:

Electricity is dangerous and can cause injury/Death , For use the instrument correctly and safely.

Pls read this manual carefully and follow the instruments.

The symbol"  "in this manual have three meanings pls pay attention the operation with "  " symbol.

 Danger— That conditions operation likely to cause serious or fatal injury.

 Warning— That conditions operation can cause serious or fatal injury.

 Caution— That conditions operation likely to cause a injury or instrument damage.

Danger

- Do not measure if the voltage is above 600V.
- Do not test at flammable / explosive hazard.
- Do not measure if the unit or your hand is wet.
- Do not go beyond the range of the tester
- Do not open the battery door when you are measuring.
- Make sure switch to off position after measured, Do not touch any bare wire during testing.

 Warning

The tester must be operated according to this manual by qualified person who have passed the training.

Do not open the case while testing. If the tester not working properly, please return for repair.

Do not replace the batteries in a humidity condition.

Make sure the wire firmly connected to the tester.

Make sure to turn off the power before open the battery door.

Check the tester regularly, do not operate if the tester is not normal (such as lead wire is cracked, the case broken etc.)

Do not attempt any alterations. Please contact your dealer if the tester need to be repaired.

 Caution





Before testing, make sure to select proper range.

Make sure switch to off position after measured, remove the battery from the instrument if it not required for extended periods of time in order to avoid eroding of battery case electrode piece resulting from a leaking battery.

Instrument wet, dry first then store.

Do not store the instrument in high temperature, humidity or under sunshine

Wipe off the dirt with a damp, soft cloth, do not use aggressive cleaning agents or solutions.

	Danger of possible Electric Shock
	Instrument with double or Reinforced
	DC
	AC
	Ground Terminal

I. Features and functions

- Auto discharge function, operate more safety
- LCD backlight
- Live wire warning and audio indication
- Auto power off in 10 minutes, without any operation
- Low battery indication

II. Specification

1 .Insulation resistance test

Rated Voltage	100v	250v	500v	1000v	2500v
Testing Range	0.0-10MΩ 10-100MΩ 100-200MΩ	0.0-10MΩ 10-100MΩ 100-500MΩ	0.0-99.9MΩ 100-999MΩ	0.0-99.9MΩ 100-999MΩ 1.00-19.9GΩ	0.0-99.9MΩ 100-999MΩ 1.0-9.99GΩ 10.0-49.9GΩ
Open Circuit	DC 100V +10%-0%	DC 250V +10%-0%	DC 500V +20%-0%	DC 1000V +20%-0%	DC 2500V +20%-0%
Rated Current	0.5MΩ 0.2mA- 0.25mA	0.5MΩ 0.5mA- 0.55mA	0.5MΩ 1mA- 1.1mA	1.0MΩ 1mA- 1.1mA	2.5MΩ 1mA- 1.1mA
Short Circuit	1.3Ma Approx				
Accuracy	±8%rdg (100K~10GΩ)		±10%rdg (10GQ-50GΩ)		

2、 Voltage Measurement

30~600V (Resolution: 1V):

	AC Voltate
Range	30~600V(50/60HZ)
Resolution	1V
Accuracy	±2% rdg ±3dgt

3. Technical specification

Parameter	Index
LCD display	Max 999 counts
Over range indication	OL: appears on insulation resistance Lo: appears on voltage
Auto range	Rang shift to upper range: 1000 counts Range shift to lower range: 95 counts (only on insulation)
Sampling rate	0.5-10 times/sec
Operation	≤2000m(indoor use)
Operation	temperature: 0°C-40°C/humidity: ≤85%
Storage	temperature: -20°C-60°C/humidity: ≤90%
Over load protection	Insulation re: AC 1200V/10sec Voltage: AC 720V/10sec
Withstand	AC 8320V(50/60Hz)/sec
Withstand Insulation	>1000MQ/DC 1000V
Power supply	DC9V(6x1.5V AA batteries)
Battery	approx. 800mA(max)
Battery life	approx. 15 hours
Dimension	125.4X174.6X69mm
Weight	547.44g (without battery and test wire)

III. Diagram of the product

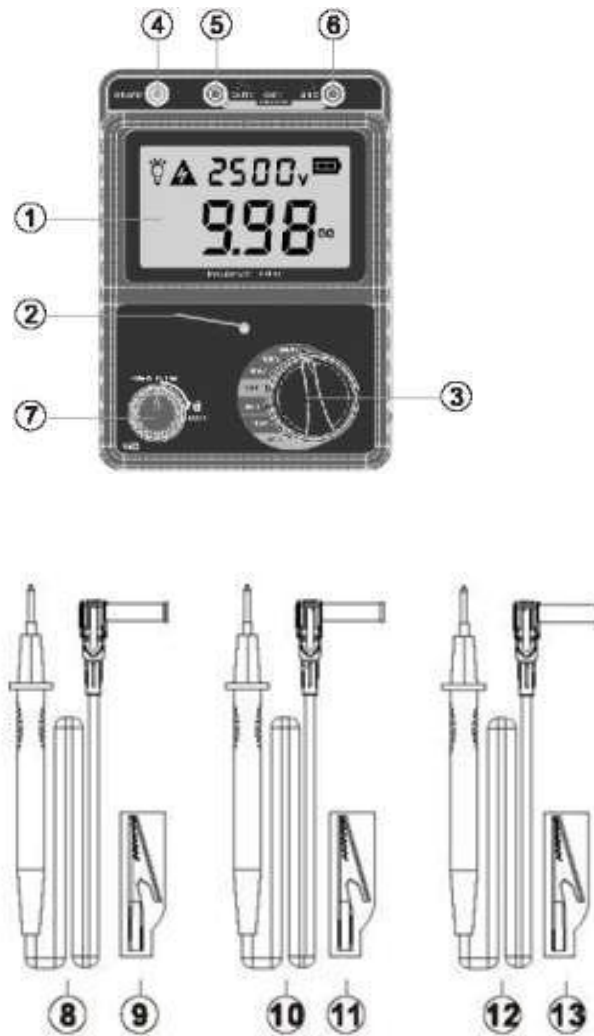









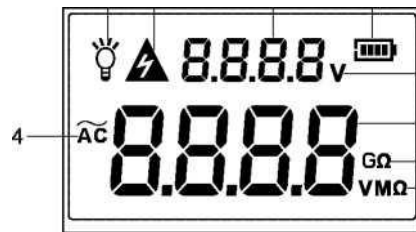

1. LCD display
2. High voltage indication light
3. Function knob
4. Socket for black Guard test wire
5. Socket for black Earth test wire
6. Socket for red Line test wire
7. Test button
8. Black Earth test wire
9. Black alligator clip
10. Red Line test wire
11. Red alligator
12. Green Guard test wire
13. Green alligator clip

Note:

Above descriptions just are simple introduction,
please read operation instructions part in this manual
for details

IV.LCD Display



1.  :Back light indication icon
2.  :High voltage warning icon
3.  : Batter power icon, shows current battery voltage as following 5 grades
 : battery is sufficient
 : battery is comparative sufficient
 : battery is nearly deficient
 : battery is nearly exhausted, need to have a replacement
 : battery is exhausted completely.
4.  : AC symbol
5. Voltage reading area
6. **V** : Unit of voltage
7. Voltage / Insulation resistance value reading
8. **GΩ** : Unit of Insulation
9. **VMΩ** : Unit of voltage / insulation

V. Operation

Preparation before measurement

1. Checking the battery power and battery replacement
 - a. Set the function switch to turn on.
 - b. When the battery icon “” shows on the LCD, it means the battery almost exhausted. Please replace the battery to avoid in-accurate measurement.
 - c. Battery replacement:
 - 1> Turn off the unit and unplug the test wires.
 - 2> Uninstall the battery door screw, and open the battery door.
 - 3> Unload the old batteries, and load the new batteries.
 - 4> After load the new batteries, put the battery door back and fasten the screw. As figure below

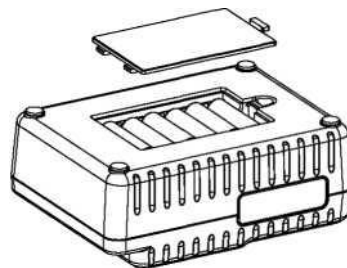

Note:

Remove the batteries from the unit if it is not required for extended periods of time in order to avoid damage resulting from leaking battery.

2. Test wires connection:

Insert the test wire firmly to the connector terminal on the instrument;

Connect the red test wire to “Line” terminal;

Connect the black test wire to “Earth” terminal;

Connect the Green guard wire to “Guard” terminal; the green guard wire only use in insulation measurement, when take measurement clamping on the shield line the avoid the current interference.

The connect method like the picture below:

Green Black Red
guard wire earth wire line wire

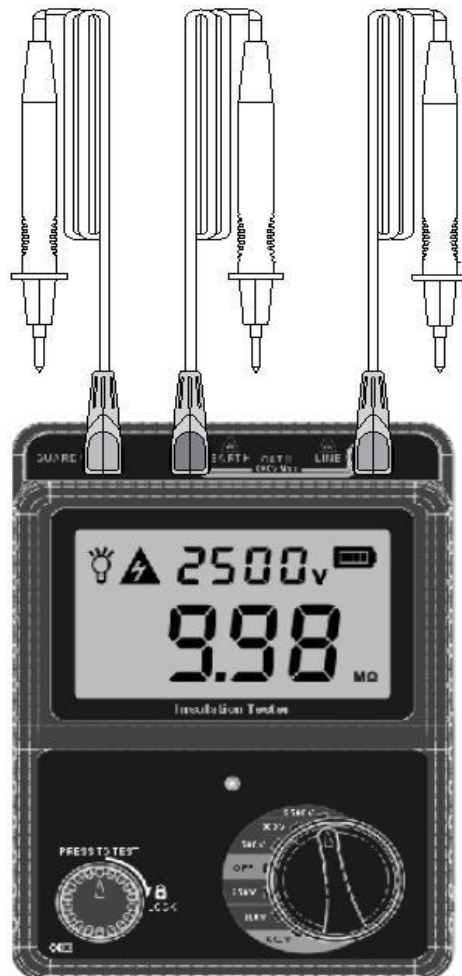

Voltage measurement(AC 30V~600V)

 DANGER

- Do not make measurement on a circuit above AC 600V
- The user maybe hazard when testing voltage that has a large current capacity, please do not touch any bare wire at this time.
- Do not make measurement with the battery cover removed.

- 1 . Connect the red、 black earth test wire to reciprocal terminal.
2. Setting the function switch to AC. V position, like the picture as below:



3、 After the full LCD display one sec, the LCD shows as below, do not press TEST button, the unit have the auto AC detection function.



4、 Connect the red black wire or pin to the tested electrode the LCD shows the reading as below:



5、 Remove the test pin from the tested parts firstly after measurement , and then set the function switch to OFF position.

Insulation resistance measurement

Danger

Make sure that there is no electrical charge exists on the circuit and Capacitor under test.

Be sure to put on a pair of insulated gloves for high voltage.

Do not make measurement when thunder rumbling.

Do not make the measurement with the battery cover removed.

Caution

When the live circuit warning is indicated or the warning buzzer sounds, measurement cannot be made at this time

1. Connect the red test wire and black test wire to reciprocal terminal.
2. Setting the function switch to proper position according to the content of insulation material, (you can take a try follow the sequence 100V/250V/ 500V/ 1000V/2500V if you do not know the resistance range) for example, 2500V like the following picture.



After full LCD display for one Sec, LCD shows as below:

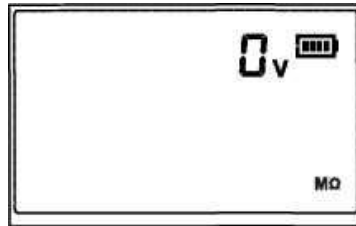

3. Connect the terminal pins/ alligators to the part undertest, press and turn TEST button to measure, the buzzer will sound continuously and the high voltage light will flash. LCD display as the figure below during the testing:

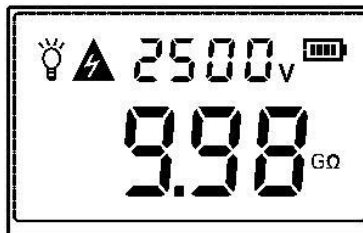

4. Release the button, the instrument will discharge the high voltage automatically, and the high voltage light and alarm sound will turn off. Remove the terminal pins/alligators only after the LCD display 0v. The insulation resistance reading display on the LCD as the figure below:

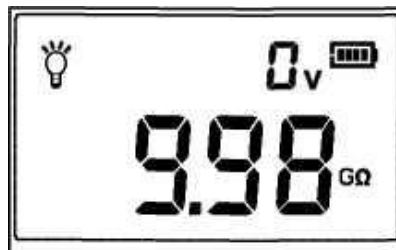

 **DANGER**

- Do not touch the circuit bare wire under test immediately after testing, capacitance stored in the circuit may cause electric shock.

5. Remove the terminal pins/alligators to the part under test then switch to “OFF” position power off.

6. The test principle of the insulation resistance:

Resistance value was triggered by applying a certain high voltage to trigger following current $R=V/I$

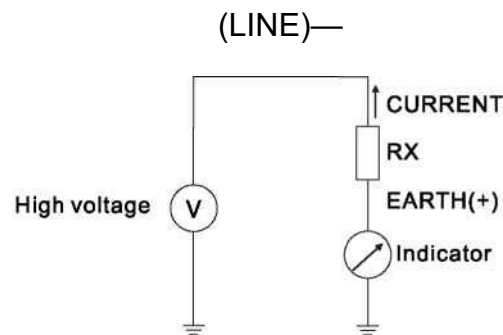

Caution

1. The unit will auto power “OFF” after 10 minutes without any operation to save the battery power, if you need to restart the unit, just turn the power switch to “OFF” position and turn on. set the power switch to “OFF” position when you do not use the instrument.
2. The “Test” switch have two test methods.
 - a. Instant measurement: Press the “Test” switch and not rotate, it will produce high voltage to test insulation release the button to stop measurement.
 - b. Continuous measurement: Press the “Test” switch and turn to lock it fbr measurement continuously, turn and release the switch will stop the measurement.

Continuous Measurement

1. About the first and second procedure, please refer “insulation measurement”.
2. Connect with the parts under test, press the TEST switch and Clockwise rotate to enter continuous measurement, the buzzer sound DiDi the LCD display as below:



Until contrarotate and release the TEST switch to original position, the high voltage indicator and Alarm will turn off gradually, instrument on testing status, release the button the unit will auto discharge the voltage .Only disconnect the testing wire after the LCD Display 0v.



3. Remove the test wires, and turn the Functional switch to “OFF” position turn off Caution

The data in the operate instruction is only for demonstration to make you understand easily, please refer it according to the measured data in practice.

Green Guard wire usage

Plug the green guard test wire into GUARD socket, the Green wire only use in insulation test, during measurement clip the guard wire to the shielded wire to reduce the interference of the current. the connecting methods as below

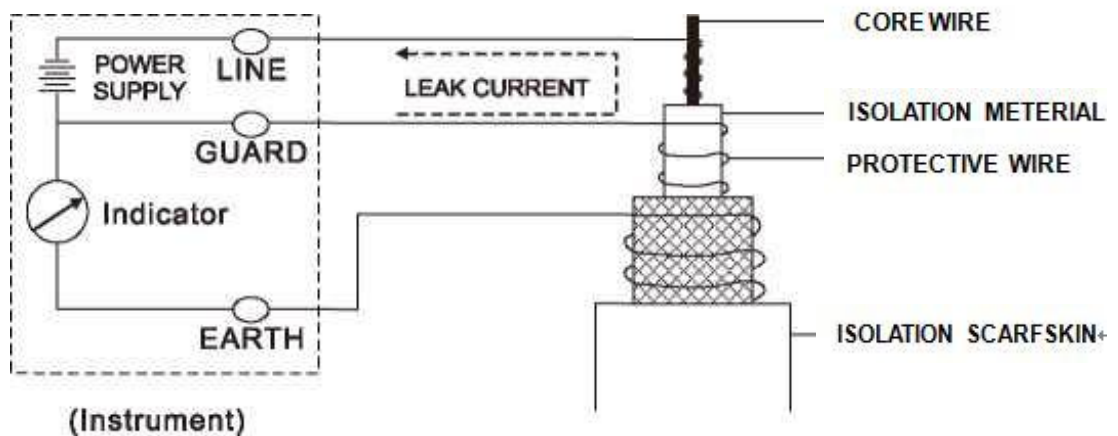

VI. Other items

Attentions

1. The screen is blank after turn on:

Check up if the batteries have been installed correctly, the “+” “-” polarity of the batteries must match the symbol inside the battery compartment.

2. If the battery power lower than $7.2V \pm 0.2V$, LCD will display low battery icon“”, please replace the batteries to prevent inaccurate readings. The replace battery method pis refer the contents of page09.

3. Remove the batteries from the unit if it is not required for extended periods of time in order to avoid damage to the battery compartment and the erosion resulting from a battery leakage.

Maintenance:

1. Do not store or use the unit in following circumstance:
 - a. Splashes of water or high levels of dust.
 - b. Air of high salt or sulphur content.
 - c. Air mixed with other gases or chemical contents.
 - d. High temperature or humidity (above 60°C, 90%RH,) or direct sunlight.
2. Do not disassemble the unit or attempt any internal alterations.
3. Never use alcohol or diluents to clean the housing for doing that will especially erode the LCD surface; just clean the unit lightly as needed with little cleanwater.