

Dear customer,

Thank you for choosing **HEY-H Transformer calibrator**. Before using the machine, please read the manual carefully. It will guide you to use the machine easily and skillfully.



Our aim is to improve the products with constant efforts, so there might be a little discrepancy exist between the real objects and the manual descriptions. We are really sorry for all the inconvenience it might cause and we'll inform you in the attached pages if any change is made. Please call our After-sale Service Department if you have any question. It's our honor to be at your service.



Considering that the input/output terminals and the test column might be electrically charged, you should pay extra attention when you plug the wire and socket, for sparks may appear in the process. Please take care of personal safety in case of electric shock.

◆Solemn Assurance

We provide free repair service if there is any quality defect within one year, dating from the day it is delivered. And we provide charged lifelong service after a year.

◆Safety Requirements

Please read the following Safety Precautions carefully to avoid personal injury or damages to the machine itself and devices connecting to it. To avoid potential danger, this machine can only be used in specified regions.

Only qualified technicians are allowed to perform the repair.

To avoid fires or personal injury, please.

Use proper power cord: Only power cord that is special for the machine or of the right gauge can be used.

Connect and disconnect correctly: Please don't connect or disconnect the test wire if it is linked with charged terminals.

Ground the machine. The grounding column of the machine shell must be earthed, except when the product is earthed through the power ground wire. To avoid electric shock, grounding conductor must be connected to earth. You must make sure that the machine is correctly earthed before connecting the input or output terminals.

Pay attention to the rated values of all the terminals. To avoid fire and electric shock, please pay attention to all the rated values and marks. Before connecting, please read the User Manual for detailed information about the rated values.

Don't operate without the cover. If the cover is removed, please don't operate the machine.

Use proper fuse. Only fuse that is of the right gauge and right rated value

can be used.

Avoid contact with exposed circuit or charged metal. If the machine is charged, please don't touch the exposed parts.

If there are potential bugs, stop the operation. If you suspect there is any damage, please call our staff for examination. And stop operating the machine right away.

Please don't operate the machine in humid and explosive environment.

Make sure that the machine surface is clean and dry.

Safety Terms

Warnings: Warnings point out dangerous practice or situations which might cause death and injuries.

Caution: Cautions point out practice or situations that might cause damage to the machine or other property.

Contents

Chapter 1	HEY-H Transformer calibrator Test Set	5
Chapter 2	Technical Parameters	13
Chapter 3	Functional Features	15
Chapter 4	Precautions	16
Chapter 5	Panel Introduction	17
Chapter 6	Operating Instructions	17
Chapter 7	Test Wiring Diagrams	22
Chapter 8	Current Generator Introduction	27
Chapter 9	CT and PT Load Case	28
Chapter 10	Instrument Transformer Test Set Software Introduction	29
Chapter 11	Transformer Wiring Diagrams from Electric Power	30
Chapter 12	Guarantee & Service	32

Chapter 1 HEY-H Transformer calibrator Test Set

1.1 Current Transformer

Current Transformer (CT for short thereafter) is very similar to general transformers. General transformers are used in the circuit to alter voltage, while CTs are used to alter current. And that's why CT was called converter. Now, devices that transform direct current (DC for short thereafter) into alternating current (AC for short thereafter) are named converters. And devices that are used to alter the magnitude of the current are named CT.

So why must we alter the current? That's because the needed current varies dramatically from a couple of Amperes (A for short thereafter) to thousands of A, according to the requirement. We would have to make a large number of ammeters and other electrical instruments if we want to measure the currents directly. This brings a lot difficulty to the manufacturing. It's also dangerous because some circuits or wires may be burdened with voltage up to 220kV. And it's not permitted to measure the current directly.

However, with CT, we are able to change the various currents to a small range that is both safe and measurable. We can measure currents of all scales with electrical instruments of only one current gauge, for example, with 5A universal current.

Besides that, the structure of CT and transformer is very much alike, both with a pair of windings, one called primary winding and the other secondary winding. And both two windings are electrically insulated from each other. When the CT is working, the primary winding W_1 is connected to the circuit and the secondary winding W_2 is connected to the electrical

instrument. Therefore, when measuring under high voltages, though the primary voltage is very high, the secondary voltage is pretty low. So the staff and the device are both safe.

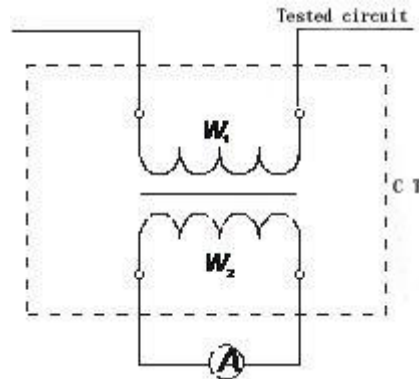

Figure 1 Current Transformer Principle Circuit

Thus, besides its convenience of changing the various currents to a small range, it also provides good insulation to ensure the safety of operators and instruments.

1.1.1 Measuring CT

Functions of measuring CT mainly involve the following 2 aspects:

(1) Security Function

Help protect the operators and instruments through insulation and isolation when measuring the current and power in circuits with high voltage.

(2) Simplicity Function

Use uniformly specified 5A secondary circuit and electrical instrument to measure large currents & power in circuits with either high or low voltage.

(3) To perform the above functions, three requests must be satisfied: first, the insulation must be reliable; second, proper precision must be achieved;

third, instrument security factor F , should be small.

(4)The secondary current is converted into primary current by rated transformation ratio. But error exists in such a convert because the actual transformation ratio is not equal to the rated transformation ratio in most cases. Thus, several accuracy classes are defined according to the error. In China, the classes include Class 0.01, Class 0.02, Class 0.05, Class 0.1, Class 0.2, Class 0.5, Class 1, Class 3, Class 5 and so on. There are detailed definition and rules about the permitted error for CT of all scales. But we can take the permitted error as 0.01%...5% corresponding to Class 0.01...Class 5 roughly when the current is near the rating.

1.1.2 Protective CT

(1) In electric power system, there is a protective circuit consists of all kinds of relay controllers to ensure normal electricity supply and the safety of valuable equipment. When the system malfunctions, the protective device will react immediately to cut off the circuit; and when the bug happens just by accident, the protective device will also be able to reconnect the circuit automatically to recover normal electricity supply.

(2)The function of protective CT is to transform current along the circuit into current of certain magnitude to power the protective devices like relays. When the current rises suddenly due to short circuit or other bugs, the current in the protective device will rise correspondingly to activate itself and cut off the malfunctioning circuit. The accuracy class of protective CT is represented by 5P or 10P, which means the permitted error is 5% or 10%.

1.2 Potential Transformer

Potential Transformer (PT for short thereafter) is a necessary device in power plant and substation for electricity supply and transmission.

PT of high precision is used in labs to expand measuring range for testing voltage, power and electric energy.

PT is very similar to general transformer, both used for alter voltage along the circuit. But the capacity of a transformer is quite large, with the unit of kVA or even MVA, because it's mainly for delivering electricity. And the capacity of PT is pretty small, generally a few VA or tens of VA, with the up-limit not more than 1000VA, because it is mainly used for the following three applications, ① provide electricity supply for test devices and relay protective device, ② measure voltage, power and electric energy of the circuit, ③ protect valuable equipment, electric machine and transformer when malfunction happens.

So why should we alter the voltage? That's because the voltage needed varies from 220V and 380V to hundreds of thousands of Volts in different circumstances of electricity generation, transmission and consumption. We would have to make a large number of voltage testers and other instruments and relays if we want to measure it directly. It's both complicated and unrealistic because it's impossible and forbidden to measure high voltage directly.

Apart from the functional similarity, PT and general transformer resemble in structure as well. Like transformers, PT also bears two windings, one called the primary winding, and the other secondary winding, with both two windings wrapping the iron core. The two windings are electrically insulated from each other and from the core. The primary winding N_1 is incorporated into the circuit in parallel, and the secondary winding N_2 is connected in parallel with instruments or relays, with the principle diagram showing as Graph 2. In this way, the secondary voltage is low despite high

primary voltage, thus ensuring the safety of the operators and the instruments.

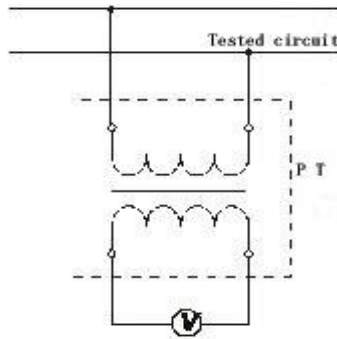

Figure 2 Potential Transformer Principle Circuit

1.3 Classification of Instrument Transformer Test Set

Instrument Transformer Test Set is mainly used to examine and assess the performance of PT and CT in lab or field application. To reach this goal, Instrument Transformer Test Set must work together with certain equipment to make up a complete suit of calibrator. The performance index of the Instrument Transformer Test Set is technically linked with the relevant equipment, so it's necessary to gain a general understanding of the Instrument Transformer Test Set itself if you want to have an overall idea of the whole device.

In China, there are three generations of Instrument Transformer Test Set. The first generation is with complex wiring and complicated operation. The second generation adopted relatively advanced electronic wiring, and the operation is easier; but in testing the gear has to be changed manually and the information showed is very limited. In the third generation, chips are widely used to make the machine more Intelligence; and some of them have computer interface, thus greatly improving the office automatic level.

Now let's cover the main features of the third generation.

(1) Chips utilizing for the implementation of measurement, control and display.

(2) Bearing computer interfaces, improving automation level, and reducing human labor.

(3) Big screen display, friendly interfaces and abundant testing information.

(4) Automatic transformer test and automatic switch of current and voltage load cases.

(5) Good capturing ability, able to report bugs in the first time.

(6) Reaching Standard 2. Most calibrator in current market adopt the method of setting a phase displacement of 90° between impedance and capacitance for data test implementation. But the disadvantage of this method is that it's easily and even badly influenced by the temperature and power frequency.

In HES- 1BX Instrument transformer test set , we adopt unique circuit principle and DSP to avoid the above problems effectively.

Classified by the test principle, Instrument Transformer Test Set can be divided into two categories, direct comparative and heterodyne measurement.

The early Instrument Transformer Test Set are designed into the direct comparative. That is, transmit the secondary currents or voltages of both the standard transformer and calibrated transformer into Instrument Transformer Test Set. After a few test circuits consisting of resistor divider, RC divider and magnetic potential comparator, we will get the current difference or voltage difference of the two transformers. And the ratio error and phase displacement between them can be obtained through

processing.

The advantage of this Instrument Transformer Test Set is that the transformation ratio of the standard transformer and calibrated transformer doesn't have to be equal. We can test directly once the rated primary voltage or current of the calibrated transformer is not bigger than that of the standard transformer. And it's easy to operate.

The disadvantage of this Instrument Transformer Test Set is that it can't be applied to transformer with the secondary load under 1VA. The error of the Instrument Transformer Test Set itself will be incorporated into the standard transformer, because the accuracy of the calibrated transformer is restricted by the element of the calibrator. For example, a Instrument Transformer Test Set with an error limit of $\pm 0.05\%$ can only be used to test transformers under Class 0.5, even with highly precise standard transformer. It can be easily seen how this disadvantage restrict the application.

Heterodyne measurement calibrator is to transmit the secondary currents or voltages of both the standard transformer and calibrated transformer into differential circuit. And get ratio error and phase displacement through calculation and testing.

Error of the calibrator itself has a much smaller impact on the final result because the error comes from the difference of the standard transformer and calibrated transformer. Generally speaking, it is OK for all classes if the standard transformer meet the request and the error limit of calibrator is not larger than $\pm 2\%$. This makes it easier to produce the calibrator and also reduce the cost, and the calibrator can be more widely used. HES- 1BX Instrument transformer test set belongs to heterodyne measurement calibrator.

HES- 1BX Instrument transformer test set is a new automatic instrument. We apply advanced electronic technology in the design. By directly decomposing the error signal, it is able to display the percentage, phase error and orthogonal error statistically. It's quick and energy saving. And it's especially good for live testing due to its cute dimension and light weight. Also, the calibrator can work under current (voltage) that is 5% of the rated value. And we can also produce calibrator of Class S and calibrator with a secondary voltage of $100/\sqrt{3}$ V, which can work under current (voltage) that is 1% of the rated value. Besides, the calibrator can perform self adjustment at any time to guarantee the precision. And we use imported elements with reliable quality which are widely used in this field.

HES- 1BX Instrument transformer test set can be applied to Class 0.01 to Class 10, CT with secondary current 1A or 5A and potential transformer with secondary voltage 100, 110, $100/\sqrt{3}$; $110/\sqrt{3}$; 120V. The result will be shown statistically, and we can equip the calibrator with RS232 interface for computer linkage.

The calibrator is able to detect the active component and reactive component of the impedance and admittance in the secondary loop.

The calibrator can indicate the polarity automatically. When the pole is reversed, the machine will cut off the differential current loop to ensure the safety of the input device, and alarm to inform the operator.

The calibrator can be used as AC potentiometer in orthogonal coordinate to test small AC current or small AC voltage.

The calibrator can cooperate with isolated PT and the operating box to test the secondary voltage of PT.

The calibrator can be normalized using standard CT or standard PT, bipolar CT, bipolar PT or inductive voltage divider.

The calibrator can take wholeness method or element method for periodic verification.

Thank you for choosing **HEY-H** . Though it's easy to operate, please read the instructions carefully.

Chapter 2 Technical Parameters

2.1 Working Condition:

(1)Temperature: 5°C-40°C Relative
humidity:<80%(25°C)
Altitude: <2500m Power Frequency:
50Hz±0.5Hz
Power Voltage: 220V±5V

(2)Measuring Range:

In-phase component(%):0.0001~200.0	Resolution: 0.0001
Orthogonal Component (min):0.001~ 700.0	Resolution: 0.001
Impedance(Ω):0.0001~20.0	Resolution:0.0001
Admittance(ms):0.0001~20.0	Resolution:0.0001

(3)Basic Error:

In-phase Component: $\Delta X = \pm(X \times 2\% + Y \times 2\%) \pm D_x$ (with Class 1 to spare)

Orthogonal Component (with Class 1 to spare)

“X”、 “Y”——Values Displayed

“D_x, D_y”——Quantified Error D_x=2, D_y=5

(4)Percentage: Class 2 (with Class 1 to spare)

2.2 Working Range:

(1) Current: (1%—149%) I_n (I_n =5A)

$$(5\% - 149\%) I_n \quad (I_n = 1A)$$

(2) Voltage: $(5\% - 149\%) U_n$ ($U_n = 100, 110, 100/\sqrt{3}; 110/\sqrt{3}; 120V$)

2.3 Work Load:

(1) Current: T_o to $T_x < 0.12\Omega$ $\cos\Phi = 1.0$

(2) Voltage: a to x $< 0.25VA$ ($100V$)

2.4 Reversed Polarity Indication

Take action according to the Polar Instructions when the current is larger than 5% of the rated value and the error is larger than 180%.

Note: If no indication comes up when the current is larger than 10% of the rated value, bug exists. On such occasions, be sure not to increase the current in case to burn the machine.

2.5 Indication of False Transformation Ratio

There should be an indication of false transformation ratio when the current is larger than 5% of the rated value and the error is between 30% and 180%.

2.6 Insulation and High Voltage Test

Terminal TX is connected with terminal ($\frac{+}{-}$)

The power socket can bear a voltage of 1.5kV with respect to the outer shell for 1 min.

2.7 Main Features of The Calibrator

(1) Application of 320×240 LCD, broad vision, long life self lighting, making it convenient to operate.

(2) All English interfaces, simple and nice.

(3) Extra—large display of percentage, ratio error and phase error,

easy to observe.

(4) Automatic sampling, rightly meet the need of JJG314—1993 and JJG314—1994.

(5) Automatic identification of polarity fault and ratio error mistake.

(6) Software can be upgraded with time.

(7) Completely solve the testing problems that Class S encounters.

(8) Automatic switch of measuring range.

(9) Perfect combination of advanced circuit technique and DSP; ultimately avoid the instability of the impedance phase differential circuit.

(10) Power consumption:

<15VA (with micro-printer)

<25VA (without micro-printer)

(11) Harmonic Suppression Ratio: >40db

(12) Size:260mm(L)×350mm(W)×150(H)

(13) Weight: 6kg

Chapter 3 Functional Features

1. Detect the phase error, ratio error of CT and PT.
2. Test the impedance of secondary load of CT.
3. Test the admittance of secondary load of PT.
4. Measure small AC current and small AC voltage.
5. Bearing RS232 interface.

Chapter 4 Precautions

1. Please read the wiring diagrams carefully before the test. Only qualified technicians have the access to operation.
2. Please call us if there is anything not clear.
3. Before connection and disconnection, please make sure that the calibrator is blackout and the machine especially the operation box is off line.
4. Check carefully before you turn on the machine; make sure of correct wiring, reliable connection and firmly grounding.
5. It's not permitted for the secondary circuit to be disconnected during CT test, and also not permitted to switch the gear of the current load case randomly.
6. During PT test, please make sure the secondary circuit is not short out. Wiring must strictly follow the wiring diagram and be safely earthed. Meanwhile, the test spot should be closed up, preventing others in, happening accident.
7. During CT test, choose the specified gears, large current wire and specific testing wires as the nameplate requires.
8. Only qualified technicians is allowed to operate the machine.
9. Please don't open any part of the machine in case of danger, and any damage due to unauthorized action is beyond our free-repair service within the valid period.
10. Please use clean and soft cloth to maintain the machine.
11. Careful move, avoid rain and longtime sunshine.

Chapter 5 Panel Introduction

The following is the calibrator panel, clear and easy for operation.



Figure 3 calibrator panel

1. LCD display, with a resolution of 320×240, showing all the testing statistics and operating indicators.
- 2, There are 18 keys on the keyboard, ↑,↓, OK, ESC, Select and Reset, “1” for printing, and “2” for data saving, the other number keys are for upgrading.
3. Power Switch
4. All the terminals are on the panel, making it safe and brief, convenient for users.
5. Printer
6. Computer interface

Chapter 6 Operating Instructions

6.1 First complete the wiring; link power; switch on; as shown in Figure 4:

(Welcome to using Instrument Transformer Test Set)



Figure 4

6.2 Press “OK” to enter the main menu, as shown in Figure 5:



Figure 5

6.3 Test object

(1) Test object: CT, PT, impedance and admittance.

(2)Secondary Current: 1A、 5A

(3)Secondary Voltage: 100, 110, $100/\sqrt{3}$; $110/\sqrt{3}$; 120V

(4)Accuracy Class of the Transformer: 1、 0.5、 0.2、 0.5S (CT) 、 0.2S (CT) 、 0.1、 0.05、 0.02、 0.01S.

6.4 Parameter Setting during CT test

During CT test, move the cursor to key \uparrow, \downarrow to choose CT, press "OK" to select the secondary current, as shown in Figure 6、 7:

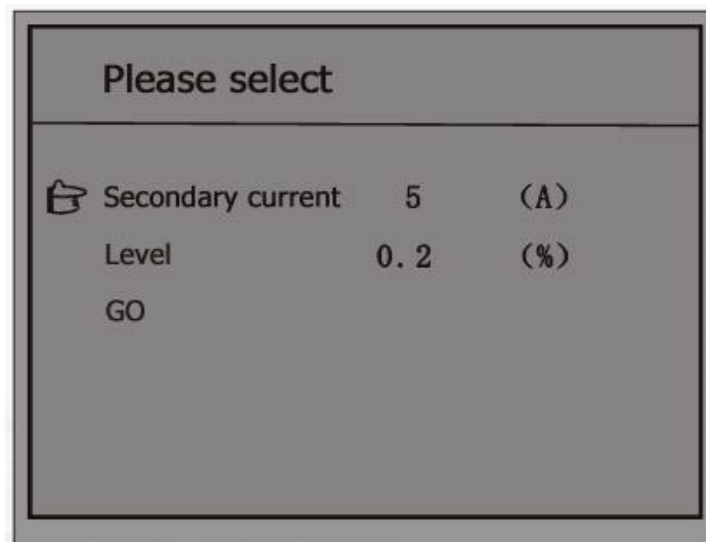

Figure 6

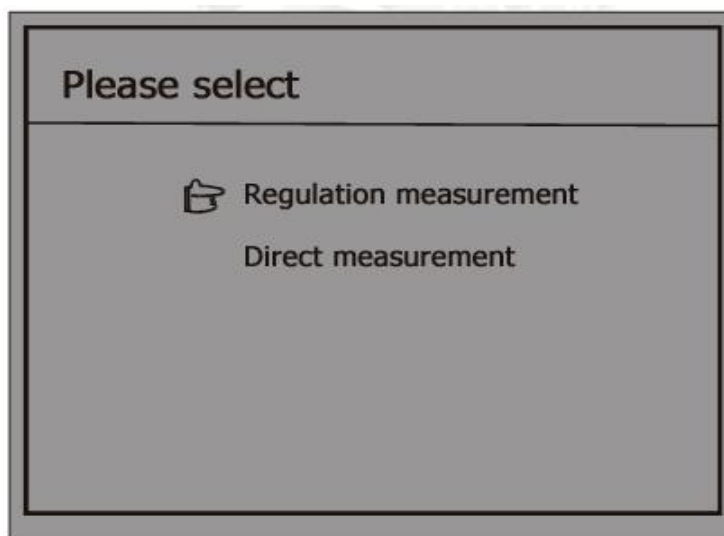

Figure 7

Note: Set the parameters according to the nameplate. Use **↑,↓,"OK", ESC** to complete the settings. Press **"OK"** to start measuring. Then you can see voltage regulator slowly rise up, and information like test object, class, precision can be seen clearly. Percentage, ratio error and phase error are in large size for convenient observation. Through this window you can see whether the error is within the precision range, as shown in Figure 8:

CT	Secondary current 5 A			Level 0.2 %	
Percentage 0.000 Ratio error 0.000 Phase error 0.000					
	1	5	20	100	120
f1 (%)	/				
d1 (,)	/				
f2 (%)	/	/	/	/	/
d2 (,)	/	/	/	/	/
f3 (%)	/				
d3 (,)	/				
Measuring, press 1 to print, press 2 to save					

Figure 8

6.5 In this interface, press **"2"**, then press **"OK"** to save the information, as shown in Figure 9:

CT	Secondary current 5 A			Level 0.2 %	
Percentage 0.000 Ratio error 0.000 Phase error 0.000					
	1	5	20	100	120
f1 (%)	/				
d1 (,)	/				
f2 (%)	/	/	/	/	/
d2 (,)	/	/	/	/	/
f3 (%)	/				
d3 (,)	/				
Measuring, press 1 to print, press 2 to save					

Figure 9

6.6 You can print on this page. Press “1” first ; then press “OK”, as shown in Figure 10:

PT	Secondary voltage 100 V			Level 0.2 %	
Percentage 0.001 Ratio error 0.000 Phase error 0.000					
	20	50	80	100	120
f1 (%)					
D1 (,)					
f2 (%)	/	/	/	/	/
D2 (,)	/	/	/	/	/
f3 (%)		/	/		/
D3 (,)		/	/		/
Measuring, press 1 to print, press 2 to save					

Figure 10

6.7 If you want to see the saved data, press ESC to enter the main menu, use ↑,↓ to reach “Data”, press “OK”, then you can have the

data as shown in Figure 11:

CT	Secondary current 5 A			Level 0.2 %	
Percentage	Ratio error			Phase error	
	1	5	20	100	120
f1 (%)	/	-0.0335	-0.1000	-0.1001	-0.1001
d1 (,)	/	0.099	0.047	0.001	0.001
f2 (%)	/	/	/	/	/
d2 (,)	/	/	/	/	/
f3 (%)	/	-0.0335	-0.1001	-0.1001	
d3 (,)	/	0.123	0.005	0.002	

Save No. 3, press 1 to save, press 2 to delete all data, press 3 to transfer

Figure 11

6.8 When finishing the test, adjust the voltage regulator to zero. Press “Reset” on the calibrator to return to the starting window. Turn off the machine and plug out power source. Disconnect the wires and put them inside the machine.

Operation for testing PT, impedance and admittance are similar to that of CT.

Users can perform the wiring referring to that of CT.

Read the wiring diagram carefully before operation. Only qualified technicians are allowed to operate it.

Please call us if you have any problem.

Chapter 7 Test Wiring Diagrams

7.1 Wiring diagram for CT calibrating CT

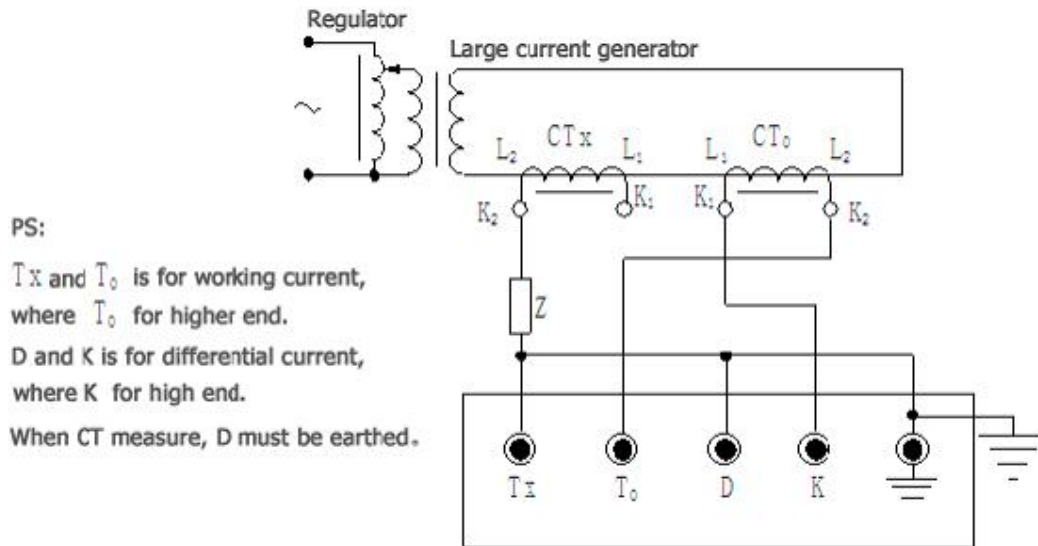

Figure 12

7.2 Wiring diagram for CT self calibration

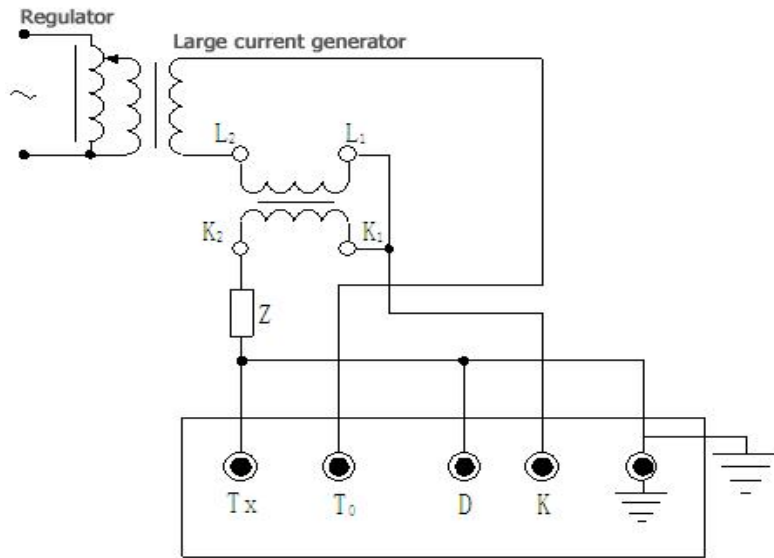

Figure 13

7.3 Bipolar CT calibrating CT

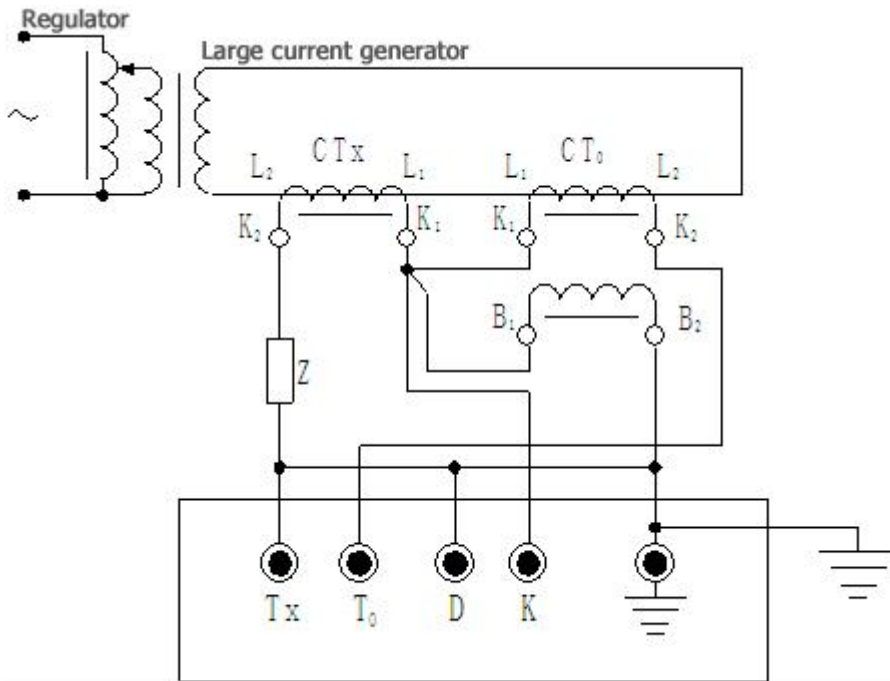

Figure 14

7.4 Wiring diagram for PT calibrating PT (Low potential port wiring)

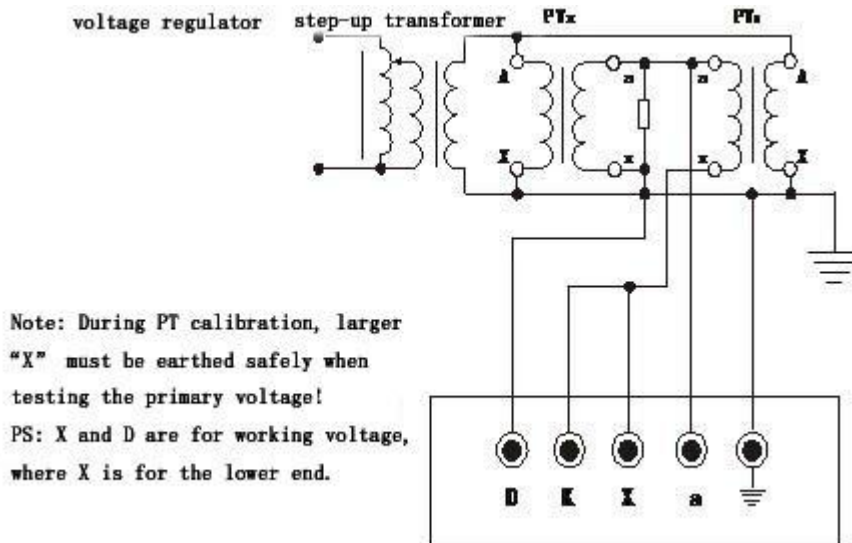

Figure 15

7.5 Bipolar CT calibrating PT

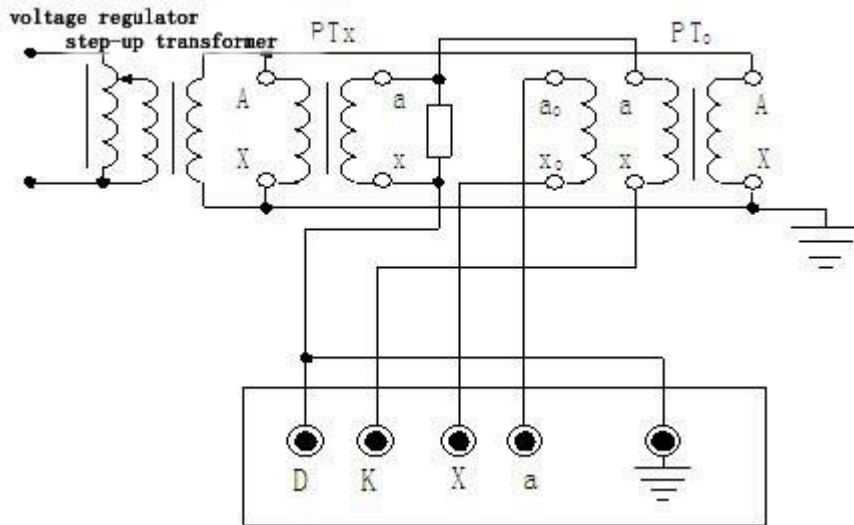

Figure 16

7.6 Wiring diagram for PT self calibration

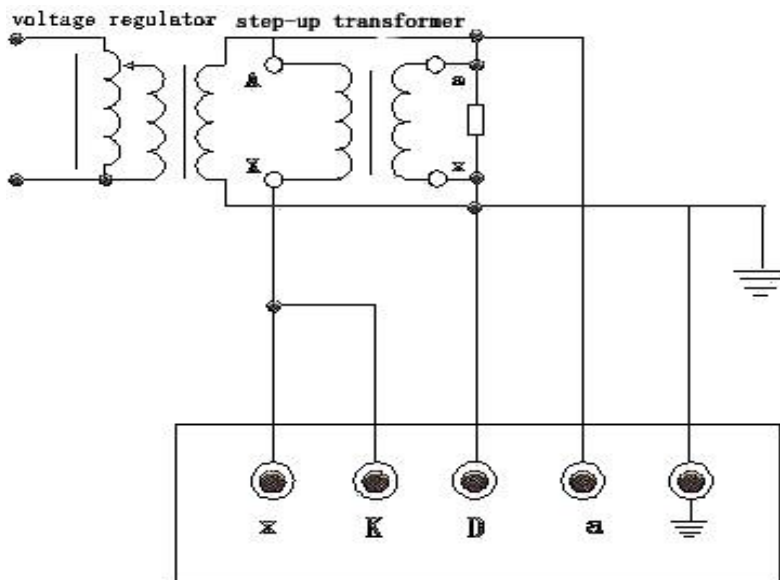

Figure 17

7.7 Wiring diagram for PT calibrating PT (High potential port wiring)

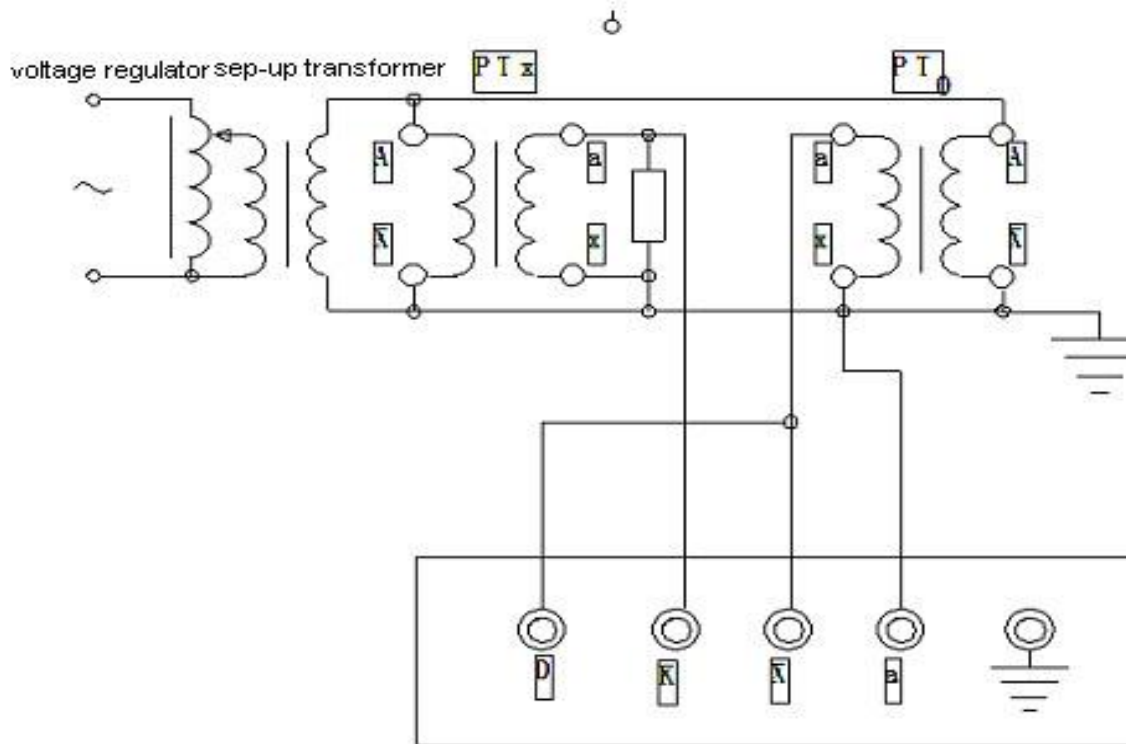

Figure 18

7.8 Impedance Test

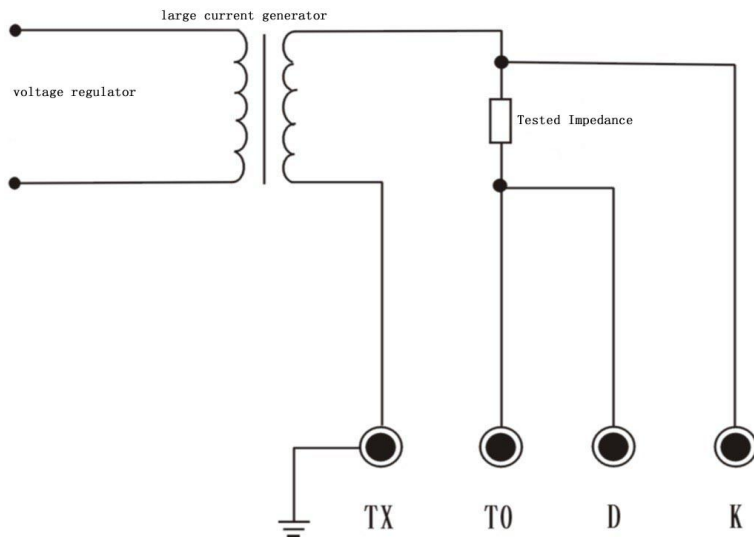

Figure 19

Precaution: Never change the load value before voltage regulator returns to zero. Or the instrument will be damaged.

7.9 Admittance Test

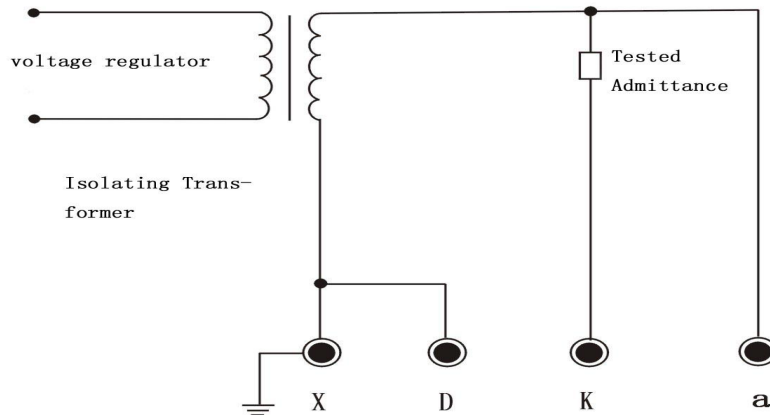

Figure 20

Precaution: Never change the load value before voltage regulator returns to zero. Or the instrument will be damaged.

Chapter 8 Current Generator Introduction

8.1 Introduction to Large current generator

Large current generator acts as the power source of primary current or other 50Hz single-phase current during CT calibration.

This device is composed of input winding (250V,±), output winding (below 100A) and cross-core winding.

The output current on nameplate refers to rated current of the cross-core winding. When it's multi-turn cross-core, the rated current will decrease in reverse proportion

Output capacity over product of output current and voltage per turn on

the nameplate leads to the maximum turn number under this output current.

With casters for moving.

8.2 Technique Index

Temperature: -5— +40°C

Relative humidity: < 80%

Long working hours under rated current.

Permitted to work for 30min when the load is 1.5 times the rated value.

Chapter 9 CT and PT Load Case

1. PT load case is connected in parallel between a and x of the tested PT.
2. CT load case should be connected in serial between K2 and TX of the tested CT.
3. Adjust the load to the actual secondary load of the CT.

PS: Some CTs use capacity to represent secondary load, in the unit of VA. And load of CT load case is generally represented by resistance, in the unit of Ω . Their relationship is as follows:

$$\text{Capacity(VA)} = \text{Resistance}(\Omega) \times \text{Secondary Current(A)} \times \text{Secondary Current(A)}$$

4. Precautions:

(1) We can design load case of specific gauge if it's requested by the customer.

(2) Wire resistance is 0.06Ω or 0.05Ω . That is to say, real resistance of the load box is 0.06Ω or 0.05Ω less than the reading value. For example, if the reading is $\cos\Phi=1$, 0.4Ω , the real resistance of load case is $0.4-0.06=0.34\Omega$; if the reading is $\cos\Phi=0.8$, 0.4Ω , the real

resistance is $0.4 \times 0.8 - 0.06 = 0.26\Omega$, the reactance is $X = 0.4 \times 0.6 = 0.24\Omega$.

(3)The current part of the load case is of Class S, reaching the precision of 1%.

Chapter 10 Instrument Transformer Test Set Software Introduction

10.1 Introduction to the management system

The aim of transformer error management system is to perform transformer test, data search and statistical reports management according to *National Metrological Verification* with the help of basic transformer data.

10.2 Main Features:

(1)Transformer management follows *National Metrological Verification*.

(2)You can type in the data manually or to choose the testing data of our unified calibrator to combine calibration and management.

(3)Calibrator control and automatic transformer test.

(4)Able to print all the records, certificates and analysis reports according to the regulations.

(5)Abundant statistical functions, able to search and integrate the conditions of instruments under test during a certain period of time, also able to summarize and assess the performance of some operator in a specific time period.

(6)Backup and recovery features.

(7) Complete teaching course and online help for users.

Chapter 11 Transformer Wiring Diagrams from Electric Power

11.1 CT Test

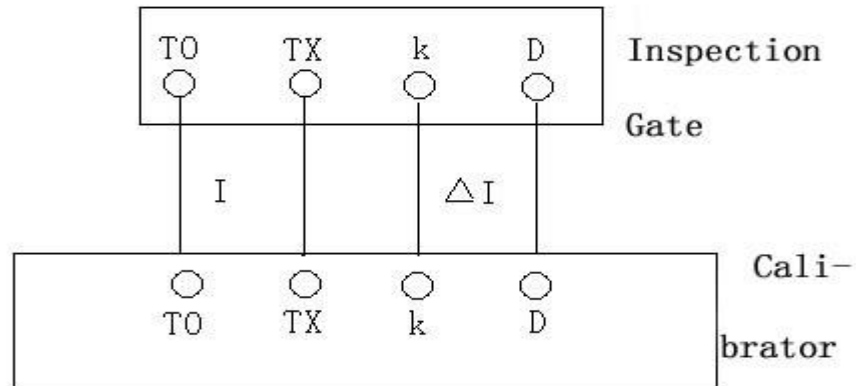

Figure 21

11.2 PT Test

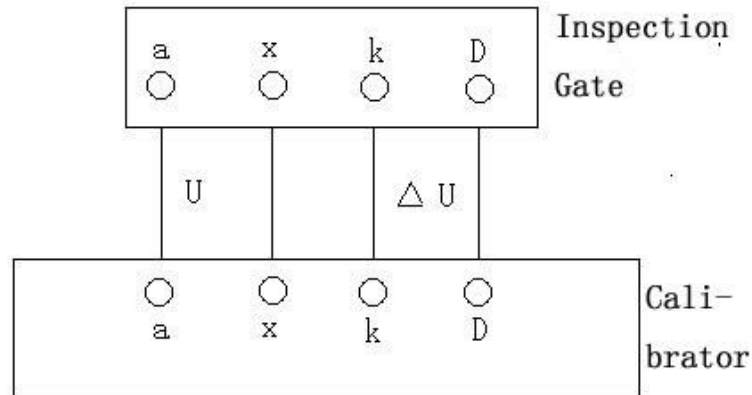

Figure 22

11.3 Impedance Test

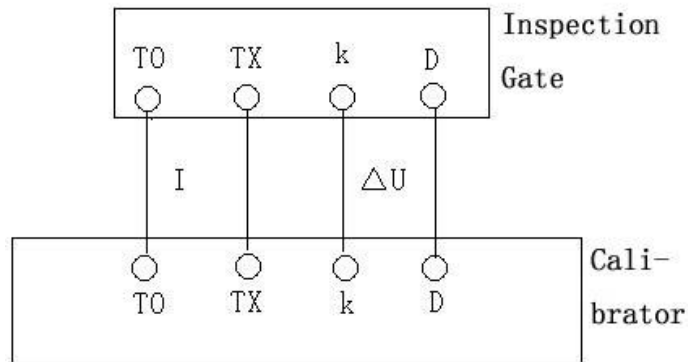

Figure 23

11.4 Admittance Test

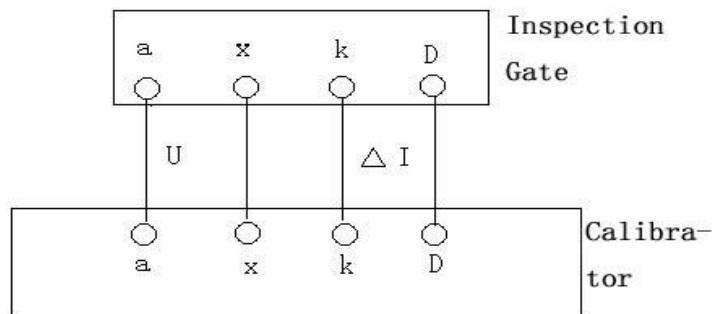

Figure 24

11.5 Operation Steps

After correct wiring referring to the wiring diagram

1. Turn on the power.
2. Select the right "Secondary Voltage/Current"
3. Select "GO" to begin the test.

Note:

1. Wiring must strictly follow the wiring diagram.
2. Before change the wire, first bring down the percentage meter, shut off, and then you can change the wire.

Chapter 12 Guarantee & Service

1. We provide free repair service if there is any quality problem within one year.
2. We provide long-term repair service with appropriate charge after one year.
3. If the machine breaks down please call for qualified technicians or sending back to us, you are not supposed to disassemble the machine by yourself, or we won't be responsible for the damage.