

Dear Client,

Thank you for Purchasing our GM-10kV Insulation Resistance Tester . Please read the manual in detail prior to first use, which will help you operate the equipment skillfully.



Our aim is to continually improve and perfect the company's products, so there may be slight differences between your purchase equipment and its instruction manual. You can find the changes in the appendix. Sorry for the inconvenience. If you have further questions, welcome to contact with our service department.



The input/output terminals and the test column may bring voltage, when you plug/draw test wire or power outlet, they will cause electric spark.

PLEASE CAUTION RISK OF ELECTRIC SHOCK!

To avoid risk of electric shock, be sure to follow the operating instructions!

Company Address:

- ◆ **T4, No. 1, High-tech 2 Road, East Lake High-tech Development Zone, Wuhan**
- ◆ Sales Hotline: 86-27- 87492243
- ◆ After Service Hotline: 13871482510
- ◆ Fax: 86-27- 87803129
- ◆ E-mail: whhuation@163.com
- ◆ Website: www.whhuation.com

◆ **SERIOUS COMMITMENT**

All products of our company carry one year limited warranty from the date of shipment. If any such product proves defective during this warranty period we will maintain it for free. Meanwhile we implement lifetime service. Except otherwise agreed by contract.

◆ **SAFETY REQUIREMENTS**

Please read the following safety precautions carefully to avoid personal injury and to prevent the product or any other attached products being damaged. In order to avoid possible danger, this product can only be used within the scope of the provision.

Only qualified technician can carry out maintenance or repair work.

--To avoid fire hazard or personal injury:

Use Proper Power Cord

Only use the power wire supplied by the product or meet the specifications of this product.

Connect and Disconnect Correctly

When the test wire is connected to the charged terminal, please do not connect or disconnect the test wire at will.

Grounding

The product is grounded through the power cord; besides, the ground pole of the shell must be grounded. To prevent electric

shock, the grounding conductor must be connected to earth ground. Before making connections to the input or output terminals of the product, please do check that the product is properly grounded.

Pay Attention to the Ratings of All Terminals

To prevent the fire hazard or electric shock, please be care of all ratings and labels/marks of this product. Before connecting, please read the instruction manual to acquire information about the ratings.

Do Not Operate without Covers

Do not operate this product when covers or panels removed.

Use Proper Fuse

Only use the fuse with type and rating specified for the product.

Avoid Touching Bare Wire and Charged Conductor

Do not touch the bare connection points and parts of energized equipment.

Do Not Operate with Suspicious Faults

If you encounter operating faults/suspect there is damage to this product, do not continue. Please contact with our maintenance staff.

Do Not Operate in Wet/Damp Conditions.

Do Not Operate in Explosive Atmospheres.

Ensure Product Surfaces Clean and Dry.

— **Security Terms**

Warning: indicates that death or severe personal injury may result if proper precautions are not taken

Caution: indicates that property damage may result if proper precautions are not taken.

Contents

Safety precautions before the experiment	6
I. Overview	7
II. Features	7
III. Main Technique Performance	8
IV. Working Principle	9
V. Panel layout	10
VI. Operation Instructions	12
VII. Problems and Solutions	14
VIII. Packing List	15
IX. Attached drawing	16

Safety precautions before the experiment

1. For safety, before use the instrument must be well earthed. That's because the measured target connects to high voltage power, and exists power frequency leakage.

2. Once high voltage has started, do not use manual discharge method to check the instrument. After test, please wait the instrument completes automatic discharge and automatically returns to zero, then manual discharge can be operated. That is because electrical pulse caused by short-circuit discharge will damage the insulation life of the measured object; if the pulse fleeing into the instrument, will also damage the integrated circuit inside the instrument.

I. Overview

With the rapid development of China's power industry, electrical preventive experiment is an important aspect of electrical power system safe operation and maintenance work. Insulation diagnosis is an important tool to detect the insulation or fault of electrical equipment

Currently, electrical equipment (such as transformers, generators, etc.) toward the trend of large capacity, high voltage, structural diversification and sealing, this requires insulation resistance tester with advantages of large capacity, strong anti-interference ability, easy to carry and so on. So we designed and developed the series meter especially for strong interference field test for large high voltage transformers, electrical appliances, remote power cables or laying cables and other electrical insulation resistance properties for high-voltage substations, power plants and others.

The instrument system combines analog circuits, digital circuits, mechanically operated advantages, achieved a leading position at the output voltage, output current, measuring range, measurement accuracy, anti-interference ability.

II. Features

1. With strong anti-electric field interference ability up to 2mA (50Hz), it is suitable for 500kV substation without dismantling wire to test insulation resistance of 500kV large-scale transformer.

2. The short-circuit current is 10mA, be suitable for testing high capacity and high inductance.

3. Wide resistance range: 0.01MΩ ~ 1999GΩ. With high-resolution, having accurate readings.

4. Wide output voltage range: 0.25kV, 0.5kV, 1kV, 2.5kV, 5kV, 10kV, adjustable, you can smoothly adjust voltage from 0V to the desired value.

5. With timing function, remind users to record, and analyze absorptance and polarization index of measured target.

6. High quality: The key parts are all imported components, to ensure accuracy and accurate.

7. Easy to use: one-piece chassis, small size, light weight, easy to carry.

8. Look beautiful: rugged and strong grinding material, the instrument's overall texture and longer life.

III. Main Technique Performance

1. Measurement voltage range: 0.25 kV, 0.5kV, 1kV, 2.5kV, 5kV, 10 kV,

2. Measurement voltage accuracy: $\pm(5\%+10V)$.

3. Short circuit current: 10mA.

4. Measurement range and accuracy

Measurement range	Resistance measurement range	Accuracy
20M Ω	0.01~19.99M Ω	$\pm(5\%+3d)$
200M Ω	5.0~199.9M Ω	$\pm(5\%+3d)$
2000M Ω	50~1999M Ω	$\pm(5\%+3d)$
20G Ω	0.5~19.99G Ω	$\pm(5\%+3d)$
200G Ω	5.0~199.9G Ω	$\pm(10\%+3d)$
2000G Ω	50~1999G Ω	$\pm(20\%+10d)$

Note:

(1) Calibration voltage of M Ω range is 0.5kV, G Ω range is 2.5kV.

(2) Ensure the accuracy of resistance measurement test voltage range: more than 20% of the nominal value of the voltage range.

(3) When the test voltage is higher than 8kV, for the accurate measurement of higher 20G Ω resistance, high voltage electrode conductor exposed to the air shield should be added to avoid the impact of air ionization.

(4) 2000 G Ω range is the reference range, its application environment: relative humidity< 70%.

5. Anti-electric field interference ability: 2mA (50/60Hz).

6. Timing and alarm functions: maximum value of stopwatch is 19 minutes and 59 seconds. 20 minutes for a cycle. The stopwatch will tell the time at these time points: 15 seconds, 60 seconds and every 60 seconds. When telling time, resistance readings hold for 3 seconds. If the measured resistance is below the lower limit of range, the reading is invalid and the instrument will continuously sound to give an alarm.

7. Display: three and a half bits LCD digital meter (three), respectively show test voltage, test resistance, test time.

8. Power supply

DC: rechargeable lithium battery, DC15V power supply. With AC (50 / 60Hz) special adapter access port to charge the battery.

9. Operating Conditions:

Temperature: $-20^{\circ}\text{C} \sim +40^{\circ}\text{C}$.

Relative humidity: 20~90%.

10. Dimensions: 315×240×180mm.

11. Weight: 5.5kg.

IV. Working Principle

It features dual division integral digital voltmeter ohm - digital conversion, this technology has a very high anti-interference ability, ohms reading unchanged when test voltage fluctuation significantly under low frequency interference.

0 ~ 10kV test voltage is excited with the feedback it generates a DC voltage converter circuit. Test voltage is high, with a strong ability to adjust automatically, so that the instrument also has the capability of non-interference is generally similar instruments is reached.

V. Panel layout

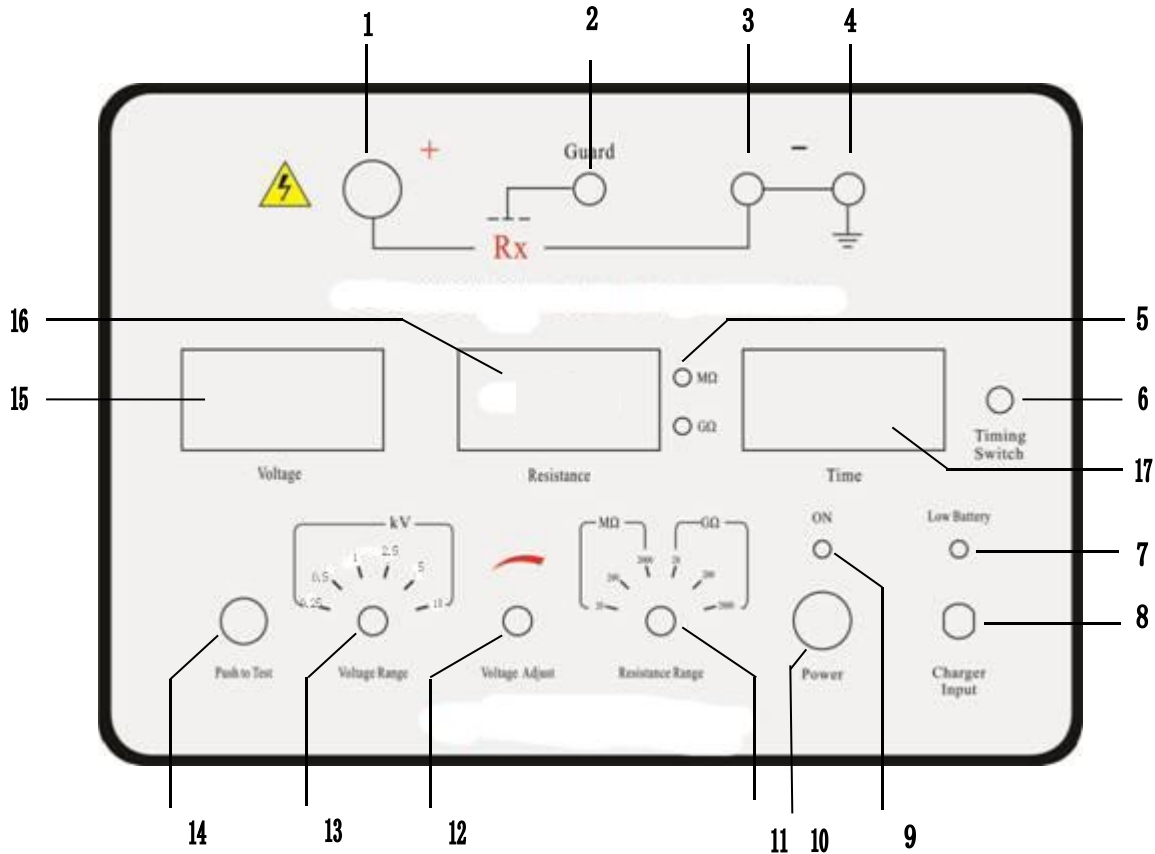

- | | |
|----------------------|---------------------------------|
| 1. +: HV output | 2. Guard: protection |
| 3/4. -: earth | 5. "Resistance gear" indication |
| 6. Timing switch | 7. low battery |
| 8. "charger input" | 9. "ON" |
| 10. Power | 11. Resistance range |
| 12. "Voltage adjust" | 13. Voltage range |
| 14. "Push to test" | 15. "kV" meter |
| 16. "MΩ/GΩ" meter | 17. "time" meter |

Note :

- "+" HV output terminal: it is also called a line terminal; it uses high-voltage cable to connect measured target such as the transformer, motor windings and cable cores.
- "Guard" protection terminal: when using "three-electrode method" measure the volume resistance of insulation material and cables, "G" should be connected to three-electrode guard ring. Guard ring is used to eliminate the

surface resistance of measured object and the leakage interference of measured circuit.

3/4. "- "ground terminal: it is the terminal that the instrument safely connects the ground and measured target. Water pipe can be used as earth terminal. Metal shell, transformer core and cable shield of motor are measured zero terminal. Earth terminal of manual discharge is also connected to this terminal.

5. "Resistance gear" indication: when switching the resistance range, the corresponding M Ω / G Ω resistance range gear will be displayed

6. "Timing switch": when the measured value is stable, press it to start timing. Display the test time in minutes and seconds, the maximum value is 19 minutes and 59 seconds, and then cycle.

7. low battery: When the working voltage is lower than 12V, the indicator light is red, and the indicator light goes out gradually with the increase of battery voltage.

8. "Charger input: When the working voltage is lower than 12V, the indicator light is red, and the indicator light goes out gradually with the increase of battery voltage.

9. "ON": The indicator light is red when the working power is on.

10. Power: the power switch of the instrument.

11. Resistance range: Adjust the rotary knob to select resistance range; range value is also the upper limit of range.

12. Voltage Adjust: Adjust the rotary knob; test voltage will smoothly rise from 0V to the desired value.

13. Voltage range: It is used to select test power value.

14. Push to test: Control the voltage measurement output. When pressed, the high voltage is output from the "+" end.

15. "KV "meter: Display the voltage value of test power between + \sim -.

16. M Ω / G Ω display screen: Display insulation resistance value. The unit of insulation resistance value decided by resistance range switch.

17. "Time" table: it shows the test duration and is also used to calculate the polarization index / absorption ratio

VI. Operation Instructions

The instrument should be charged before use (full charge time is 8 hours, its indicator light change from red to green), in order to avoid power-off during test. In addition, please use reference resistance and attachment apparatus to check whether the instrument work properly and accurately.

Operation method as follows:

1. Preparation

Before wiring, make sure power switch is in "off" position, HV control knob is in "exit" state. Measured target has disconnected power; all measured terminals should be grounded via manual discharging rod. All these are safe, you can connect wire.

For some measured targets suffering strong interference due to power leakage such as substations, power plants, before wiring please complete and carefully confirm above four operations, in order to avoid the risk of electric shock. You can remove the manual discharging rod after completed connecting wire.

2. Connect wire

Connect the two "-" terminal of the instrument to ground terminal/zero terminals of measured target and the earth.

Connect "+" terminal to measured target such as transformer winding and cable core.

Connect "Guard" terminal to protection ring of measured circuit in order to eliminate the impact of surface resistance leakage.

3. Preselect test power

Counter-clockwise rotate "HV Preselect knob" to the desired value, display value will increase from 0V to the maximum value.

4. Turn power supply on

Turn power supply on, the indicator light above it will glow, "kV" voltage meter display 0.00kV.

5. Test start

Press the "high voltage control" button, and the high voltage will be output from the + terminal. The "kV" meter will display the voltage value between + -. Press the "timing switch" and the "timing" meter will start timing.

6. Test power adjustment

Adjust the "high voltage adjustment" knob to smoothly adjust the voltage to the specified value

7. Resistance range selection

Adjust the range switch to select the desired range. If the meter continuously give an alarm indicating the measured resistance is too low, please adjust to low range for measuring.

8. Reading resistance value

Read the resistance value through the "MΩ / GΩ" meter. After the resistance value is stable, press the "timing switch" stopwatch to report the time in 15 seconds, 60 seconds and every 60 seconds after the high-voltage output for the convenience of the operator to record. The formula of absorptance and polarization index as follows:

absorptance = R_{60S}/R_{15S} -- resistance reading of the 60th seconds ÷ resistance reading of the 15th seconds.

Polarization Index = R_{10min}/R_{1min} -- resistance reading of the 10th minutes ÷ resistance readings of the 1st second.

9. Exit test power

Press "push to test" to exit test power, at this time "KV" display will slowly return to zero and the stopwatch will display exit.

10. End

When the "kV" display screen shows 0.00kV, then the measured target has completed discharge via the manual discharging rod, you can turn power

off and remove the wire.

VII. Problems and Solutions

1. Instrument problems and solutions

No.	Problem	Reason	Solution
1	Power light is off work	The battery voltage is less than 12V	Please charge timely
2	Shell discharge	The instrument has not be grounded	Safe ground!
3	Charge time is more than 8 hours, but the indicator light has not turned green.	Battery damage	Remove the battery, renew a set of batteries.
4	No HV output	Due to overload the dynatron is burned out	Replace power dynatron BU406 and its prepositive dynatron C2482
5	Output voltage is high, and you cannot adjust.	Amplifier damage	Replace CA3140 op amp on high-voltage circuit board.
6	Resistance displays a fixed value -1 or other fixed value.	Amplifier damage	Replace double integral AD conversion Manifold
7	Resistance readings swings or out-of-tolerance	Most are caused by strong interference, such as strong discharge, measured cable swinging or insulating property error	Use reference resistance to check.

2. The battery charging circuit of the instrument is charged according to the constant voltage and current limiting charging method. It takes about 6-8 hours to fully charge each time. The fully charged battery can supply the instrument for 6-8 hours of continuous operation. In order to ensure the battery life, the storage period of the instrument shall be charged once every three months.

VIII. Packing List

1. Instrument Host	1
2. HV Cable	2
3. Connect Line	2
4. Ground wire	1
5. Power Cord	1
6. Reference Resistance (1GΩ)	1
7. The instruction manual	1
8. Inspection report	1
9. Certificate	1

IX. Attached drawing

Insulation resistance measurement wiring diagrams for substation transformer and cable:

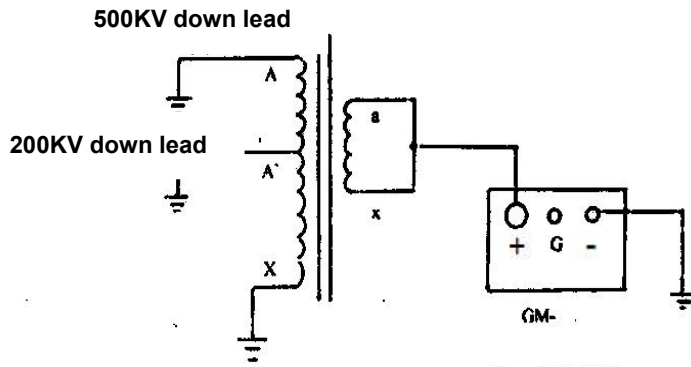

500KV power transformer LV winding insulation test wiring diagram

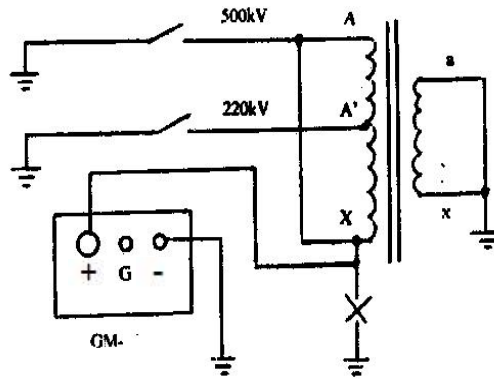

500KV power transformer HV winding insulation test wiring diagram

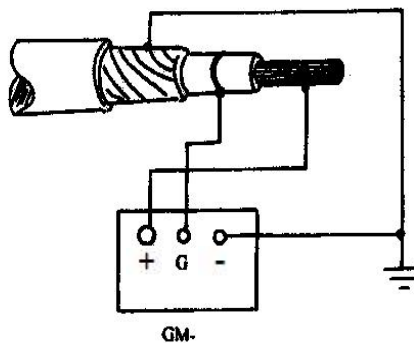

Shielded cable insulation test wiring diagram